

Harvard Apparatus Pumps Catalog

Legendary performance for every application



- Superior Quality
- Legendary Reliability
- Expert Technical Support
- Highest Accuracy & Precision
- Over 100 years of Fluidics Experience

Harvard Apparatus Pumps

Running a syringe pump has never been easier.

Harvard Apparatus offers a broad selection of syringe, peristaltic and continuous flow pumps to suit almost every application. Syringe pump models have been expanded to include new innovative pumps with the widest range of flow rates and forces of any manufacturer. With more than 100 years of success and a proven track record of designing and manufacturing high quality reliable syringe and peristaltic pumps, only Harvard Apparatus has the scientific depth and fluidics knowledge to recommend the right pump and accessories for your application. Our superior technical experts are available to assist you from start to finish.

Harvard Apparatus invented the lead screw based syringe pump in the 1950's and introduced the first microprocessor pump, in the 1980's. Our syringe pumps are so accurate, even at low flow rates, that they have become the standard for mass spectrometry calibration, animal infusion and anywhere accurate volumes must be delivered.

Our PHD ULTRA™ and Pump 11 Elite Series have set a new standard in syringe pumps. They are easy to use with an intuitive interface controlled via touchscreen. The PHD ULTRA™ and Pump 11 Elite are suitable for a wide range of applications including mass spec calibration, drug and nutritional studies, macro to micro reactors, LP chromatography, electrospinning, aerosols and microfluidics to microfluidics. The Pump 11 Pico Plus Elite is best suited for low flow rate studies and small volume injections. It is ideal for applications including: microdialysis, animal drug and nutritional studies, cellular injection, and more.

The Pump 33 DDS provides two independently controlled syringe pump channels in one syringe pump. When combined with a valve box, the Pump 33 DDS can also provide the continuous flow of a peristaltic pump with the smooth flow of a syringe pump.

Results you can count on!

Since 2011, there have been more than 2,000 scientific publications referencing the use of Harvard Apparatus pumps in areas including: infusion, microfluidics, perfusion, electrospinning, and more. You can count on our expert

technical support to provide product recommendations and application support to advance your studies.

If you don't find what you need, please contact us! Our technical support and engineering teams can assist in creating special pumps or custom pumping systems to meet your requirements.

Harvard Bioscience is a global developer, manufacturer and marketer of a broad range of specialized products, primarily apparatus and scientific instruments used to advance life science research at pharmaceutical and biotechnology companies, universities and government laboratories worldwide.

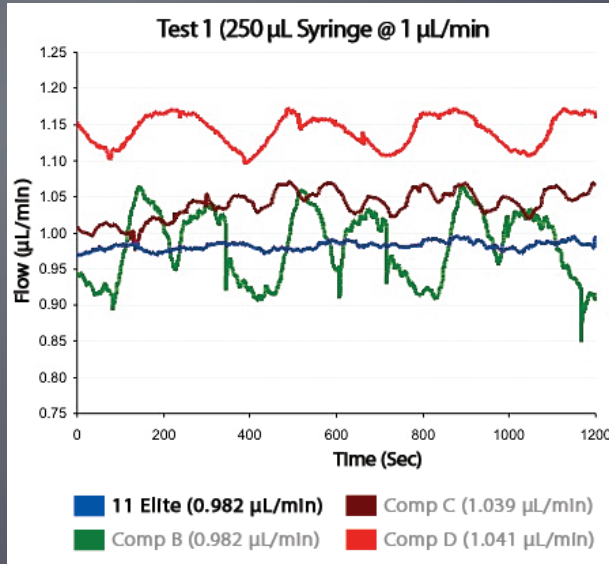

Performance

All pumps are not created equal. The graph above shows the flow profiles of the Pump 11 Elite versus three similar competitive pumps run under the same conditions. When volume accuracy and flow stability are important to your experiments, only Harvard Apparatus delivers.

Table of Contents

SYRINGE PUMPS

PRODUCT	PAGE
Syringe Pump Selection Guide	4
Syringe Pump Application Guide	5-6
Application Selection Guide	7-9
Pump 11 Elite	10-12
Pump 11 Pico Plus Elite	13
Pump 11 Elite Nanomite	14
PHD ULTRA™ Advanced Syringe Pumps	15-18
PHD ULTRA™ Push/Pull Syringe Pump	19
PHD ULTRA™ CP Constant Pressure Syringe Pump	20-21
PHD ULTRA™ 4400	22-23
Harvard Apparatus Pump Controller	24-26
Syringe Pump Solutions for System Integrators – Pump Modules and Open Baseplate Configurations	27
PUMP 33 DDS (Dual Drive System)	28-29
FlowControl™ Software	30



Pump 11 Elite Nanomite, page 16

SYRINGE PUMP ACCESSORIES

PRODUCT	PAGE
Continuous Delivery Valve Box	31
Pressure Transducers for PHD ULTRA™ CP Syringe Pumps	32-35

SYRINGES

PRODUCT	PAGE
Stainless Steel Syringes	36-37
Hamilton™ Glass Syringes	38-42
Specialty and Plastic Syringes	43-44



PHD ULTRA™ Syringe Pump, pages 19

PERISTALTIC PUMPS

PRODUCT	PAGE
Peristaltic Pump Selection Guide	45-46
Harvard Peristaltic Pumps.....	47-48
Harvard Peristaltic Pump P-1500 with Weight Scale.....	49
MPII Mini-Peristaltic Pump.....	50
Instech Model 720 Compact Peristaltic Pumps.....	51
Single and Multiple Channel Peristaltic Pumps, Pump Heads	52-60

PERISTALTIC PUMP ACCESSORIES

PRODUCT	PAGE
Tubing Cassettes, Tubing and Connectors.....	61-66



Pump 11 Elite Syringe Pump, page 11

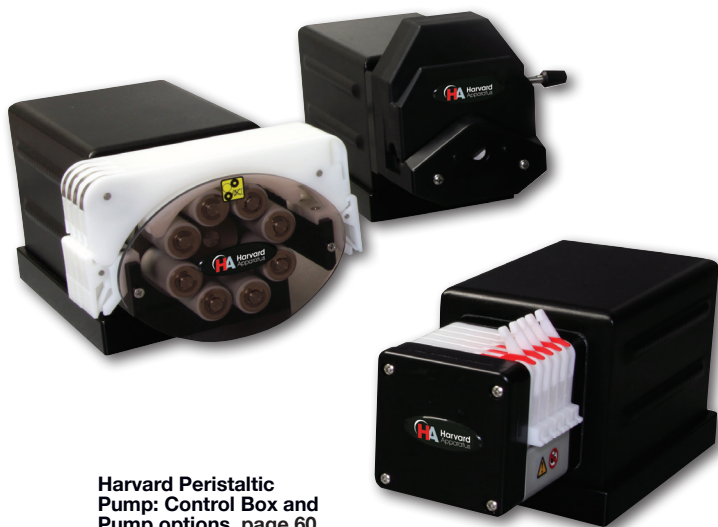

Harvard Peristaltic Pump: Control Box and Pump options, page 60



BLOOD PUMPS

PRODUCT	PAGE
Centrifugal Pumps for Blood.....	67
Pulsatile Blood Pumps.....	68-69

TUBING

PRODUCT	PAGE
Priming Kit, Compression Fittings and PEEK Tubing.....	70
Tubing.....	71-80

CONNECTORS AND VALVES

PRODUCT	PAGE
Tubing Connectors, Stopcocks, Valves.....	81-87

PUMP REFERENCES

PRODUCT	PAGE
Pressure, Flow Rates and Syringe Information ...	88-96

Choosing the Right Pump – Specifications

SYRINGE PUMP QUESTIONS

- What is your application?
- How many syringes will be used simultaneously?
- What size syringe will be used?
- What flow rate(s) will be used? See pump reference pages 109-111
- What is the total volume to be delivered?
- Does the pump need to withdraw (fill the syringe) as well as infuse (dispense)?

SYRINGE PUMP QUESTIONS (CONTINUED)

- What is the viscosity of the liquid you are pumping?
See pump reference page 88
- What are the pressure requirements of your experiment?
See pump reference pages 88
- Does the pump need to continuously infuse over a 24 hour period of time?
- Does the pump need to be programmable?
- Will the pump be operated from a pump display/
Or will the pump be controlled via a PC or logic level controller?
- Does the pump need to have TTL capabilities (ex. external control of valves, use of footswitch, etc)?

Selection Guide										
	INFUSION ONLY		INFUSION/WITHDRAWAL						PUSH/PULL	
MODEL	PUMP 11 ELITE	PHD ULTRA™	PUMP 11 ELITE	PUMP 11 PICO PLUS ELITE	PUMP 11 ELITE NANOMITE	PHD ULTRA™ & PHD ULTRA™ CP	PHD ULTRA 4400	PHD ULTRA™ XF SYRINGE PUMP	PUMP 33 DDS	PHD ULTRA™ PUSH/PULL
SEE PAGE	11	19	11 & 15	14 & 15	15 & 16	17 & 19	27		30	24
STANDARD PUMP	70-4500 70-4501	70-3005	–	–	–	70-3006 88-3015	–	70-3514	PCS 70-3333	70-3008
PROGRAMMABLE PUMP	–	–	70-4504 70-4505	70-4506 70-4511	70-4507	70-3007	70-3010 70-3310		–	70-3009
NUMBER OF SYRINGES	1 or 2	2 to 10*	1 or 2	2	1	2 to 10*	1	4	2	4 (2 on each side of pusher block)
MINIMUM SYRINGE SIZE	0.5 µl	0.5 µl	0.5 µl	0.5 µl	0.5 µl	0.5 µl	0.5 ml	20 ml	0.5 µl	0.5 µl
MAXIMUM SYRINGE SIZE	50/60 ml (single) 10 ml (dual)	140 ml	50/60 ml (single) 10 ml (dual)	50/60 ml (single) 10 ml (dual)	1 ml	140 ml	140 ml	200 ml	60 ml**	140 ml***
MINIMUM FLOW RATE	1.26 pl/min	1.50 pl/min	1.26 pl/min	0.54 pl/min	3.66 pl/min	1.50 pl/min	3.06 pl/min	50.79 nl/min (using 20 ml syringe)	1.02 pl/min	1.50 pl/min
MAXIMUM FLOW RATE	88.40 ml/min (single) 26.02 ml/min (dual)	216.0 ml/min	88.40 ml/min (single) 26.02 ml/min (dual)	39.77 ml/min (single) 11.70 ml/min (dual)	3.82 ml/min	216.0 ml/min	216.0 ml/min	144.3 ml/min (using 200 ml syringe)	106 ml/min	216.0 ml/min
AVERAGE LINEAR FORCE	16 kg (35 lb) (adjustable)	34 kg (75 lb) (adjustable)	16 kg (35 lb) (adjustable)	16 kg (35 lb) (adjustable)	5 kg (11 lb) (adjustable)	34 kg (75 lb) (adjustable)	91 kg (200 lb) (adjustable)	454 kg (1000 lb) 100% force selection	31.75 kg (70 lb per syringe) (adjustable)	34 kg (75 lb) (adjustable)
COMPUTER CONTROL	USB	USB + RS-232	USB	USB	USB	USB + RS-232	USB + RS-232	USB + RS-232	USB + RS-232	USB + RS-232
I/O + TTL CONNECTION	No	Yes	Yes	Yes	Yes	Yes	Yes	Yes	Yes	Yes
DIMENSIONS (H x W x D)	22.6 x 17.78 x 15 cm (9 x 7 x 6 in)	10.16 x 30.5 x 21.6 cm (4 x 12 x 8.5 in)	22.6 x 17.78 x 15 cm (9 x 7 x 6 in)	22.6 x 17.78 x 15 cm (9 x 7 x 6 in)	22.6 x 17.78 x 9.32 cm (9 x 7 x 3.67 in)	10.16 x 30.5 x 21.6 cm (4 x 12 x 8.5 in)	30.5 x 21.6 x 10.8 cm (12 x 8.5 x 4.25 in)	10.16 x 30.48 x 21.59 cm (4 x 12 x 8.5 in)	28 x 39 x 21 cm (12 x 15 x 8 in)	10.16 x 30.5 x 21.6 cm (4 x 12 x 8.5 in)
PUMP HEAD DIMENSIONS (H x W x D)	–	–	–	–	6.35 x 5.08 x 19.05 cm (2.5 x 2.0 x 7.5 in)	–	–	–	–	–
WEIGHT	2.1 kg (4.61 lb)	4.5 kg (10 lb)	2.1 kg (4.6 lb)	2.1 kg (4.61 lb)	1.96 kg (4.32 lb)	4.5 kg (10 lb)	6.4 kg (14 lb)	3.7 kg (30.2 lb)	9.09 kg (21 lb)	4.5 kg (10 lb)

Please contact Technical Support for assistance. See Page 29, Syringe Pump Solutions for System Integrators

- * Depends upon the Syringe Rack
 - 4 x 140 Syringe Rack Holds four 60 ml or 140 ml plastic syringes only
 - 6 x 10 Syringe Rack Holds six 30 to 60 ml syringes or ten 0.5 µl to 20 ml syringes
 - Microliter Syringe Rack Holds four 0.5 µl to 10 ml syringes

** Some larger syringes may be compatible with the Pump 33 DDS. Please contact Technical Support for assistance.

*** Push/Pull pump can hold syringes up to 140 ml if full stroke is not required. Larger syringes will not fully infuse or withdraw. Max of 50 ml syringe if full stroke is required.

Choosing the Right Pump for Your Application & Budget

Find your application and go to the pages indicated for more information!

Application Guide					
	STANDARD SYRINGE PUMPS				
	PUMP 11 ELITE	PUMP 11 PICO PLUS ELITE	PUMP 11 ELITE NANOMITE	PUMP 33 DDS	PHD ULTRA™
SEE PAGE	11	14	16	30	19
ACCURATE DELIVERY OF COATINGS		X			X
ANIMAL FEEDING	X				X
BULK FLUID TRANSFER				X	X
CELL CULTURES	X			X	X
CELLULAR INJECTION		X	X		X
CONSTANT PRESSURE INFUSIONS					
CONTINUOUS INFUSIONS				X	
DOPING	X				X
DRUG DELIVERY (SAME INFUSION RATES)	X			X	X
DRUG DELIVERY (DIFFERENT INFUSION RATES)	X			X	
DRUG DELIVERY (TIME RELEASED)	X				X
DRUG DEVELOPMENT	X			X	X
ELECTROSPINNING	X			X	X
FLUID BLENDING	X				X
FLUID BLENDING (2 INDEPENDENT CHANNELS)				X	
FLUID SAMPLING	X	X	X		X
GRADIENTS	X				X
HIGH PRESSURE INJECTION					
HIGHLY CORROSIVE FLUIDS					
HPLC	X	X		X	X
INJECTING INTO HIGH PRESSURE REACTION VESSELS		X			
INJECTION PRESSURE CALCULATIONS	X				X
INSTRUMENT INJECTIONS	X				X
LOW PRESSURE CHROMATOGRAPHY	X			X	X
MASS SPECTROMETRY	X	X		X	X
MEDICAL COATING DELIVERY				X	X
MICRODIALYSIS	X	X			X
MICROFLUIDICS	X	X			X
MRI STUDIES					
MULTIPLE SIMULTANEOUS FEEDING STATIONS	X			X	X
NANOFUIDICS		X			X
NUTRITIONAL STUDIES	X				X
OEM MODULES					
OOCYTE APPLICATIONS		X	X		X
PATCH CLAMPING					X
REMOTE PUMPING OF HAZARDOUS MATERIAL			X		X
STEM CELL INJECTIONS					
STEREOTAXIC INJECTIONS			X		
TITRATIONS	X			X	X
VISCOUS SOLUTIONS		X			X

Choosing the Right Pump for Your Application & Budget

Find your application and go to the pages indicated for more information!

Application Guide					
	STANDARD SYRINGE PUMPS				
	PUMP 11 ELITE	PUMP 11 PICO PLUS ELITE	PUMP 11 ELITE NANOMITE	PUMP 33 DDS	PHD ULTRA™
SEE PAGE	11	14	16	30	19
ACCURATE DELIVERY OF COATINGS		X			X
ANIMAL FEEDING	X				X
BULK FLUID TRANSFER				X	X
CELL CULTURES	X			X	X
CELLULAR INJECTION		X	X		X
CONSTANT PRESSURE INFUSIONS					
CONTINUOUS INFUSIONS				X	
DOPING	X				X
DRUG DELIVERY (SAME INFUSION RATES)	X			X	X
DRUG DELIVERY (DIFFERENT INFUSION RATES)	X			X	
DRUG DELIVERY (TIME RELEASED)	X				X
DRUG DEVELOPMENT	X			X	X
ELECTROSPINNING	X			X	X
FLUID BLENDING	X				X
FLUID BLENDING (2 INDEPENDENT CHANNELS)				X	
FLUID SAMPLING	X	X	X		X
GRADIENTS	X				X
HIGH PRESSURE INJECTION					
HIGHLY CORROSIVE FLUIDS					
HPLC	X	X		X	X
INJECTING INTO HIGH PRESSURE REACTION VESSELS		X			
INJECTION PRESSURE CALCULATIONS	X				X
INSTRUMENT INJECTIONS	X				X
LOW PRESSURE CHROMATOGRAPHY	X			X	X
MASS SPECTROMETRY	X	X		X	X
MEDICAL COATING DELIVERY				X	X
MICRODIALYSIS	X	X			X
MICROFLUIDICS	X	X			X
MRI STUDIES					
MULTIPLE SIMULTANEOUS FEEDING STATIONS	X			X	X
NANOFLUIDICS		X			X
NUTRITIONAL STUDIES	X				X
OEM MODULES					
OOCYTE APPLICATIONS		X	X		X
PATCH CLAMPING					X
REMOTE PUMPING OF HAZARDOUS MATERIAL			X		X
STEM CELL INJECTIONS					
STEREOTAXIC INJECTIONS			X		
TITRATIONS	X			X	X
VISCOUS SOLUTIONS		X			X

Application Selection Guide

Since 1901 Harvard Apparatus has been supporting bioresearch fluidics requirements with a key milestone being the introduction of the first commercial syringe pump for bioresearch in 1956. Since 1956, over 70,000 satisfied syringe pump users around the world have made Harvard Apparatus syringe pumps the worlds #1 choice. Harvard Apparatus has a wealth of experience to share in recommending the right solution for your application. Following is only a partial guide of some application suggestions. Contact our Technical Support group for their input or with questions for the best pump to meet your need.

If you do not see what you feel is the best solution for your application, give us a call as we often develop or modify standard products for particular applications.

Neuroscience

Applications in this area include: microdialysis and site specific microinjection into various brain regions.

- For stereotaxically guided, single channel microinjection, see the Pump 11 Elite Nanomite on page 16, or the PHD ULTRA™ Nanomite on page 28.
- For single or dual probe microdialysis, see the Pump 11 Elite on page 11 or Pico Plus Elite on page 14.
- For applications using a liquid switch, or for running multiple experiments simultaneously, see the PHD ULTRA™ on page 19.

Infusion and Drug Delivery

Delivering accurate volumes and flows is critical to maintaining dosing regimens, interpretation of pharmacokinetics and other data.

- For single or dual channel infusions, see the Pump 11 Elite on page 11, or PHD ULTRA™ on page 19.
- To run multiple studies from a single pump, see the PHD ULTRA™ on page 19.

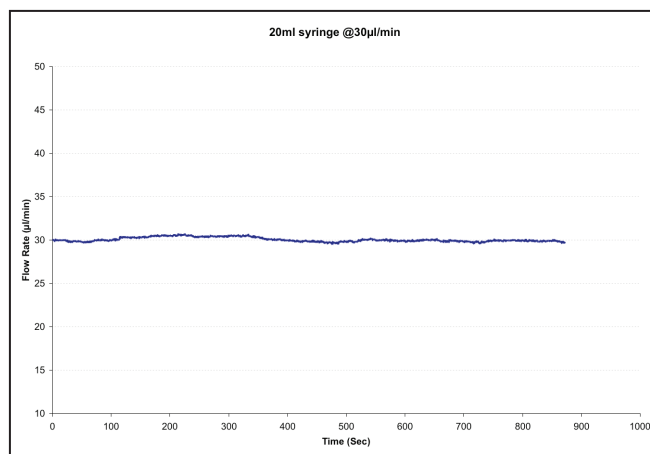
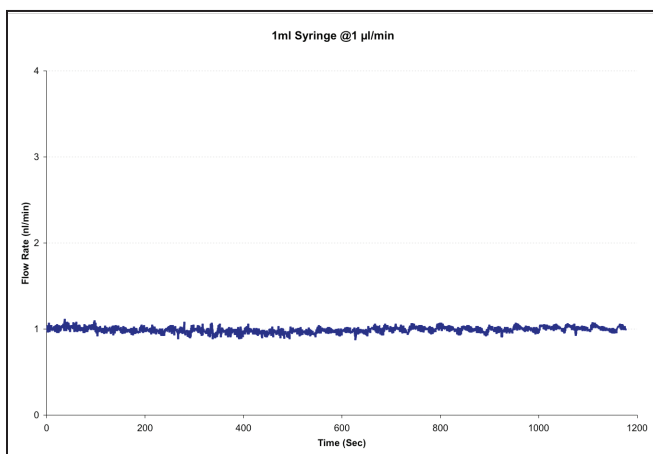

Application Selection Guide

Cell Biology

Cellular studies typically involve the injection of very small volumes under controlled conditions. Several models offer a foot pedal accessory to start/stop flow on command.

- For cellular microinjections of plasmids, viruses, and the like, see either the Pump 11 Pico Plus Elite on page 14, PHD ULTRA™ Nanomite on page 28 or the Pump 11 Elite Nanomite on page 16.

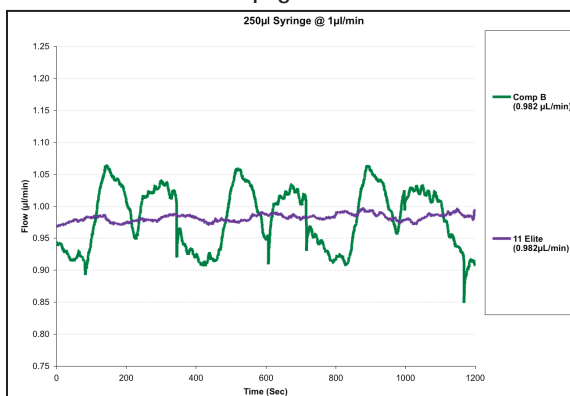

Cell Biology References

Microfluidic electroporation for selective release of intracellular molecules at the single-cell level, **ELECTROPHORESIS**, Volume 29, Issue 14, pages 2939–2944,

No. 14 July 2008

L-selectin-mediated lymphocyte-cancer cell interactions under low fluid shear conditions, **THE JOURNAL OF BIOLOGICAL CHEMISTRY**, 283, 15816–15824

Chemical & Industrial/Electrospinning

Where chemical synthesis, pressurized systems, and other applications demand high performance Harvard Apparatus has the right solution. For high pressure applications, consider the PHD ULTRA™ 4400 on page 27.

Harvard Apparatus pumps are used in creating Nano and Micro scale polymer fibers

in a high voltage field. The stability of flow and flexibility of use, in the PHD ULTRA™ series pumps, makes it easy to alter the variables relating

to successful electrospinning. Our pumps include a grounded power supply and can be supplied with a grounding strap, which will shunt any high voltage arcs to ground.

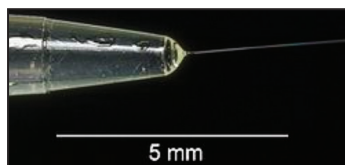

Mass Spectrometry Calibration and Electrospray Ionization

Calibration and Electrospray Ionization

Where precise volume delivery and pulse free flow are required for optimum instrument calibration or solvent elimination, the Pump 11 series has long been the industry standard for manufacturers in OEM configurations and end users. See the Pump 11 Elite on page 11, and Pump 11 Pico Plus Elite systems on page 14.

Additionally, use of the gradient capabilities of the Pump 11 Elite or PHD ULTRA™ Series allows for automated multi-point calibration when performing GLP studies.

MALDI-TOF Matrix Addition

Using the Nanomite with its detachable delivery and electronics allows for easy placement of the syringe over the target to facilitate the dispensing of the appropriate matrix. See the

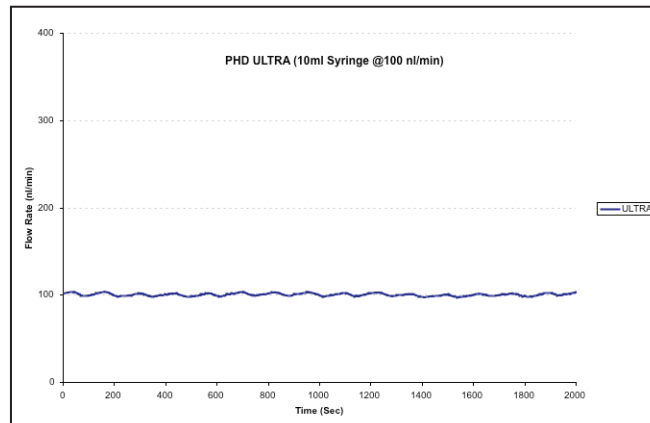

Application Selection Guide

Microfluidics

The PHD ULTRA™ series and Pump 11 Elite series pumps have the performance and flow stability required in micro and nanofluidics. These pumps can be used to mix flow streams and/or create multiple parallel flow streams. Another option is the NanoLeader pressure pump that can push and/or pull fluids using positive or negative air pressure, creating the smoothest flow possible.

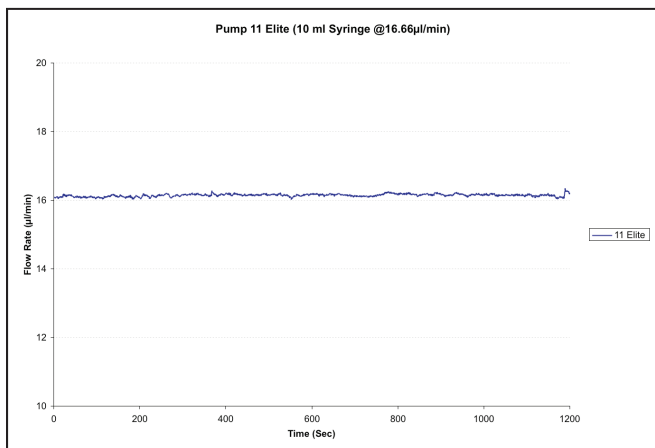

Nano/Micro Liquid Chromatography

The advanced programming capabilities of the PHD ULTRA™ and the Pump 11 Elite Syringe Pumps allow for the easy generation of binary or ternary gradients at flow rates ranging from 100 nL/min to 1.0 ml/min at pressures up to 7,500 PSI. Depending on the number of syringes used, up to one liter of mobile phase may be delivered from each pump used.

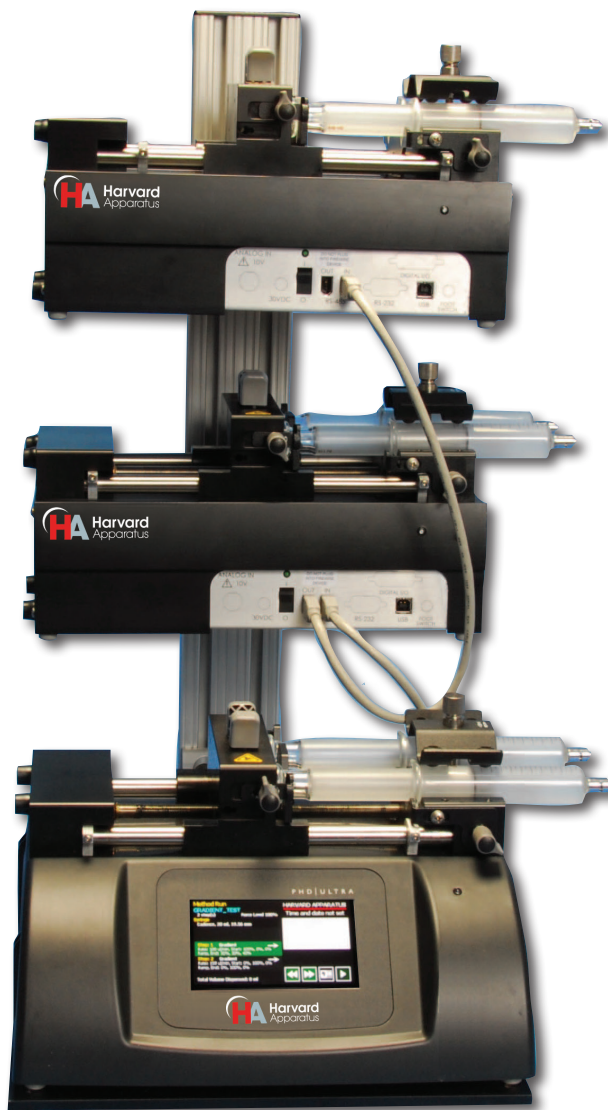

Pump 11 Elite



KEY FEATURES

- Easy-to-use touchscreen and icon interface
- Outstanding flow performance
- Easily run simple to complex methods without a PC
- Alphanumeric keypad for easy Method naming and recall
- Adjustable linear force up to 35 lb
- Upgrade new versions of software remotely
- Legendary reliability – 2 year warranty

APPLICATIONS

- Microfluidics
- Drug/Nutritional Delivery
- Microdialysis
- Emulsification
- Bioreactors
- Electrospinning
- Mass Spectrometry

The Pump 11 Elite Series of syringe pumps expands its capabilities to satisfy your experimental requirements. These compact syringe pumps carry on the tradition as the premier workhorse infusion pump, offering unparalleled ease of use with a high resolution color touchscreen with intuitive icon interface. The Pump 11 Elite Series allows you to create, save and run simple to complex methods without a PC.

Superior Performance

These syringe pumps have a mechanism that includes a tight gripping, very secure syringe clamp for syringes ranging from 0.5 μ l to 60 ml (single syringe) and 0.5 μ l to 10 ml (dual syringe). The Pump 11 Elite Series offers enhanced flow performance with high accuracy and smooth flow from 1.26 pl/min to 88.40 ml/min (26.02 ml/min for dual syringe rack).

The Pump 11 Elite Series is available in Infusion Only or Infusion/Withdrawal Programmable Models with single or dual syringe racks. All Pump 11 Elite syringe pumps have a footswitch input and USB serial port for computer control. The Infusion/Withdrawal Programmable models also have RS-485 (or optional RJ-11) ports for daisy chaining pumps and Digital I/O for external control via an independent computer or device (see page 13 for more information on connectivity).

The Pump 11 Elite Series is a family of accurate, low flow syringe pumps designed for use in applications including: mass spec calibration, drug and nutritional studies, reactor dosing, electrospinning and more.

Easy-to-Use Interface

The Pump 11 Elite Syringe Pumps are very easy to use with an LCD color touchscreen and icon interface. The Message Area of the touchscreen is used to display helpful instructions for the currently displayed screen. It is also used to display error or warning messages to indicate problem conditions in a Method or error conditions during pump operation. The Run Screen shows all of the pump parameters on one screen for easy review.

The software is organized into three main navigational branches, the quick start Methods, user-defined Methods, and system settings. You can control operations directly through the touchscreen or remotely from an independent computer or device via the external I/O interface.

Pump 11 Elite

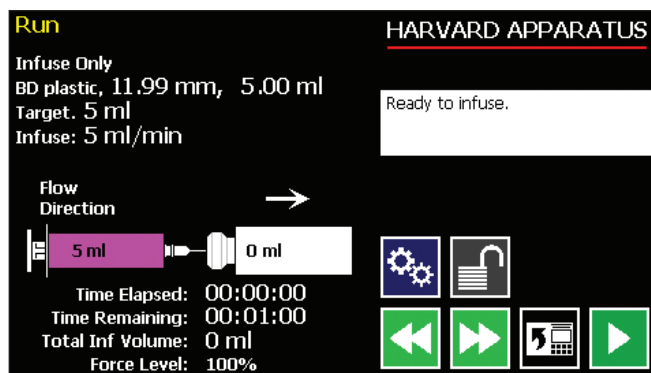
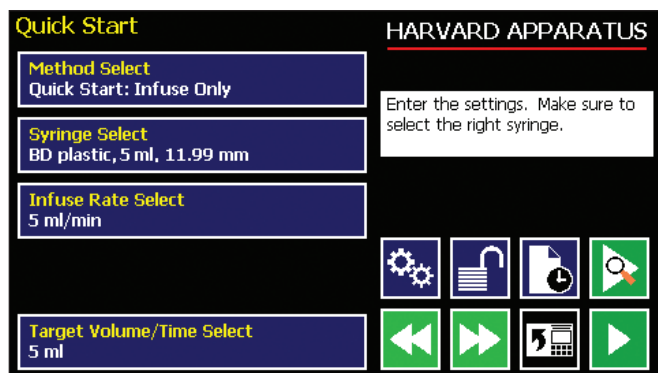

Pump Models

The Pump 11 Elite Syringe Pumps are available in two configurations designed for different operating environments and varying degrees of operational flexibility.

- 1. Infusion Only (single and dual syringe models):** This model supports infusion operations at user-defined flow rates and with selectable target volume or time values to control the total infusion volume. The Infusion Only models do not include programmable, user-defined Methods.
- 2. Infusion/Withdrawal Programmable (single and dual syringe models):** This model supports infuse only, withdraw only, infuse/withdraw and withdraw/infuse operations at user-defined flow rates and with selectable target volume or time. This model also allows users to create and store up to two user-defined Methods of 50 steps each on the pump.

Accessories

A full range of accessories are compatible with the Pump 11 Elite including syringe heaters, in-line heaters and coolers, nanofluidic circuits, connectors, tubing, syringes and more.

Program Description

To operate the Pump 11 Elite, the user defines all the required parameters for infusing or withdrawing liquids through a Method. This may be a Quick Start Method, Pre-Programmed or User-Defined Method. The basic operation is a simple 3-step procedure:

1. Select a method
2. Enter operating parameters
3. Preview or Run your method

Quick Start Methods are simple infusions, withdrawals or a combination (depending upon the model). Custom user-defined Methods can be created when more advanced programming is required. The setup for a custom Method is easy using the standard profiles found on all Infusion/Withdrawal Programmable Elite Models. The list of available profiles is:

By programming custom (user-defined) Methods into the pump, multi-user errors are reduced. Easily transfer Methods to other pumps and/or download Methods from a PC. Forget having to duplicate Method-development efforts for each new pump added to your system.

Alarms

There are several alarms available on the Model 11 Elite Syringe Pumps:

- End of Run
- Near End of Run
- Power Up
- Stall

Advanced Documentation Features

- Download experimental parameter information to PC
- Alphanumeric keypad for method naming

Adjustable Force

The maximum linear force of the Pump 11 Elite is 16 kg (35 lb). Depending upon the syringes you are working with and your overall experimental setup you may want to adjust the amount of force applied to the pusher block. You can select a percentage of the total force from 20% to 100%. Refer to the user's manual for suggested force level settings.

CONTROL MULTIPLE PUMPS VIA DAISY CHAIN WITH RS-485



Pump 11 Elite

Advanced Connectivity

The infusion only Pump 11 Elite Syringe Pumps come standard with a Footswitch input and USB connector. The infusion/withdrawal programmable Pump 11 Elite Syringe Pumps include a Footswitch input, USB, RS-485 and I/O connectors. There is also an option for RJ-11 connectors on the programmable pumps. This option has to be ordered at the time the pump is ordered.

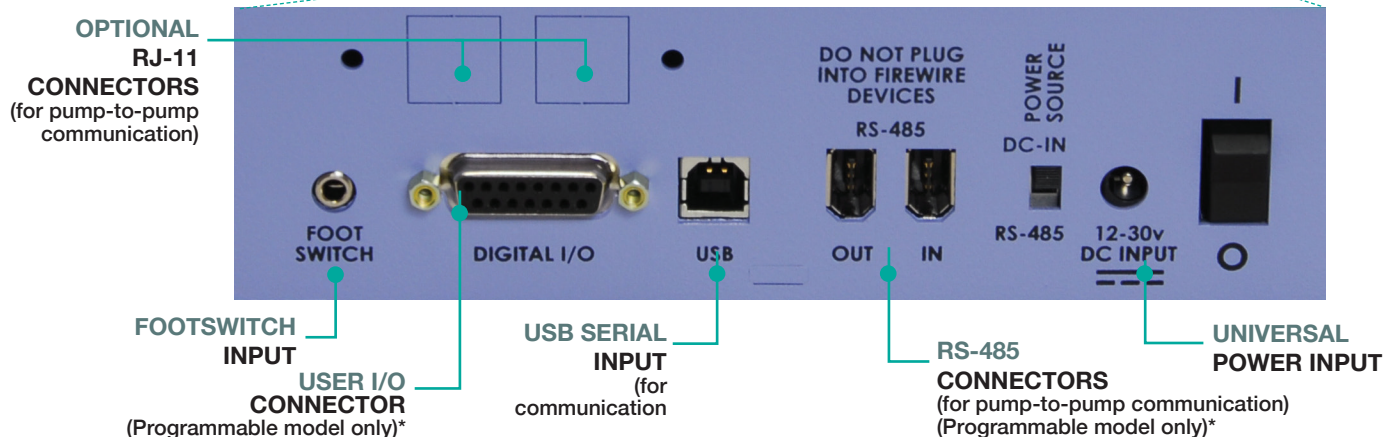
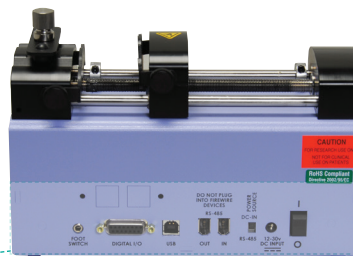

Pump 11 Elite Specifications	
TYPE	Microprocessor single or dual syringe, infusion only or infusion/withdrawal programmable
ACCURACY	±0.5%
SYRINGE:	
Type	Plastic or glass
Size (single syringe)	0.5 µl to 50/60 ml
Size (dual syringe)	0.5 µl to 10 ml
FLOW RATE:	
Single Syringe	1.26 pl/min to 88.4 ml/min
Dual Syringe	1.26 pl/min to 26.02 ml/min
DISPLAY	4.3" WQVGA TFT color display with touchscreen
CONNECTORS:	
RS-485	IEEE-1394, 6 position*
USB	Type B
I/O & TTL	15-pin D-Sub Connector*
Footswitch	mini phono jack
AVERAGE LINEAR FORCE	16 kg (35 lb) @ 100% Force Selection
STEP RESOLUTION	0.069 µm/µstep
INPUT POWER	12-30 VDC
INPUT POWER CONNECTION	2.5 mm ID x 5.5 mm OD male plug
POWER SUPPLY	100 to 240 VAC, 50/60 Hz, 18 Watts Universal Power Supply, Use Only a Harvard Apparatus Approved Power Supply and Line Cord
DIMENSIONS, H x W x D	22.6 x 17.78 x 15 cm (9 x 7 x 6 in)
WEIGHT	2.1 kg (4.6 lb)
REGULATORY CERTIFICATIONS	CE, ETL (UL, CSA), WEEE, EU RoHS & CB Scheme

FOOTSWITCH INPUT	Start and stop a pump
USB SERIAL INPUT	Control your pump with a computer
RS-485 CONNECTORS	Connect multiple pumps together (daisy chain up to 99 pumps) Connect satellite pumps to the Master pump for binary gradient system (% composition)
RJ-11 CONNECTORS (OPTION)	Connect multiple pumps together (daisy chain)
USER I/O CONNECTOR	
DIRECTION CONTROL INPUT	Set pump to infuse or withdraw
TRIGGER INPUT	Connect an external device to start and stop a pump or Method
TRIGGER 1 OUTPUT	Signal another device to start and stop a pump or Method

Order #	Product
70-4500	Pump 11 Elite Infusion Only Single Syringe
70-4501	Pump 11 Elite Infusion Only Dual Syringe
70-4504	Pump 11 Elite Infusion/Withdrawal Programmable Single Syringe
70-4505	Pump 11 Elite Infusion/Withdrawal Programmable Dual Syringe
Accessories	
70-4000	RS-485 Cable for Pump-to-Pump Communication, 0.5 m (1.6 ft)
70-4001	RS-485 Cable for Pump-to-Pump Communication, 2 m (6.6 ft)
70-4020	RS-485 Extension Cable, 9.1 m (30 ft)
70-4002	USB Cable for PC-to-Pump Communication, 2 m (6.6 ft)
70-4003	USB Cable for PC-to-Pump Communication, 5 m (16.4 ft)
70-4006	Adapter, D-sub 15 to Term, Blk
72-8340	Adapter, USB to Serial
70-2215	Footswitch (with Phono Plug)
70-3030	RS-232/RJ11 CONNECTOR OPTION
55-7760	Cable Assy, Daisy Chain, Legacy RS-232 RJ-11, 0.6 m (2 ft) For use only with 70-3030 RS-232/RJ11 Connector Option
55-8000	Adapter for 25 ml, Hamilton GasTight™ Syringes

Pump 11 Pico Plus Elite



70-4506 Pump 11 Pico Plus Elite Infusion/Withdrawal Programmable Dual Syringe



70-4511 Pump 11 Pico Plus Elite Infusion/Withdrawal Programmable Single Syringe

KEY FEATURES

- Easy-to-use touchscreen and icon interface
- Outstanding flow performance
- Easily run simple to complex methods without a PC
- Alphanumeric keypad for easy Method naming and recall
- Adjustable linear force up to 35 lb
- Upgrade new versions of software remotely
- Legendary reliability – 2 year warranty

APPLICATIONS

- Microfluidics
- Drug/Nutritional Delivery
- Microdialysis
- HPLC
- Cellular Injections
- Mass Spectrometry

The Pump 11 Pico Plus Elite is the lowest flow, highest accuracy syringe pump. It offers enhanced flow performance with high accuracy and smooth flow from 0.54 pl/min to 39.77 ml/min (single syringe version) or 0.54 pl/min to 11.70 ml/min (dual syringe version). This precision syringe pump offers unparalleled ease of use with a high resolution color touchscreen with intuitive icon interface. The Pump 11 Pico Plus Elite allows you to create, save and run simple to complex methods without a PC.

The Pump 11 Pico Plus Elite is a dual syringe Infusion/Withdrawal Programmable Model. It has a footswitch input, USB serial port for computer control, RS-485 ports for daisy chaining pumps and Digital I/O for external control via an independent computer or device (see page 13 for more information on connectivity). There is also an option of daisy chaining pumps through the RS-232 (RJ-11) ports. For more information on the Pump 11 Pico Plus Elite including features and programming see the Pump 11 Elite on page 11.

Pump 11 Pico Plus Elite Specifications

TYPE	Microprocessor single and dual syringe, infusion/withdrawal programmable
ACCURACY	±0.35%
SYRINGE:	
Type	Plastic or glass
Size (Single Syringe)	0.5 µl to 50/60 ml
Size (Dual Syringe)	0.5 µl to 10 ml
FLOW RATE:	
Minimum	(Single/Dual) 0.54 pl/min
Maximum	(Single) 39.7 ml/min (Dual) 11.7 ml/min
DISPLAY	4.3" WQVGA TFT color display with touchscreen
CONNECTORS:	
RS-485	IEEE-1394, 6 position
USB	Type B
I/O & TTL	15-pin D-Sub Connector
Footswitch	Mini phono jack
AVERAGE LINEAR FORCE	16 kg (35 lb) @ 100% Force Selection
STEP RESOLUTION	0.031 µm/µstep
INPUT POWER	12 to 30 VDC
INPUT POWER CONNECTION	2.5 mm ID x 5.5 mm OD male plug
POWER SUPPLY	100 to 240 VAC, 50/60 Hz, 18 Watts Universal Power Supply, Use Only a Harvard Apparatus Approved Power Supply and Line Cord
DIMENSIONS, H x W x D	22.6 x 17.78 x 15 cm (9 x 7 x 6 in)
WEIGHT	2.1 kg (4.6 lb)
REGULATORY CERTIFICATIONS	CE, ETL (UL, CSA), WEEE, EU RoHS & CB Scheme

Order #	Product
70-4511	Pump 11 Pico Plus Elite Infusion/Withdrawal Programmable Single Syringe
70-4506	Pump 11 Pico Plus Elite Infusion/Withdrawal Programmable Dual Syringe

Pump 11 Elite Nanomite



KEY FEATURES

- Easy-to-use LCD color touchscreen with GUI interface
- Light weight makes it ideal for hand-held or stereotaxic injection
- Easily program simple to complex Methods without a PC

APPLICATIONS

- Cellular Injections
- Drug Delivery
- Microinjections
- Hand-Held Automated Delivery
- Stereotaxic Injections
- Regenerative Medicine

The Pump 11 Elite Nanomite is a single syringe infusion/withdrawal programmable syringe pump. This pump allows you to create, save and run simple to complex Methods without a PC. The flow rate range is 3.66 pl/min to 3.82 ml/min with 11 lb of adjustable force across the entire flow rate range.

The Pump 11 Elite Nanomite has a footswitch input, USB serial port for computer control, RS-485 ports for daisy chaining pumps and Digital I/O for external control via an independent computer or device. There is also an option for daisy chaining pumps through the RS-232 (RJ-11) ports. This option must be ordered at the time the pump is ordered. See page 13 for more information on connectivity.

This pump consists of a control unit, an injection unit, a 6 foot cable to connect the two units and a footswitch. For more information on the Pump 11 Elite Nanomite including features and programming, see the Pump 11 Elite on page 11.

For filling small volume syringes & needles, see the HA Priming Kit on page 86.

Pump 11 Elite Nanomite Specifications

TYPE	Microprocessor single syringe, infusion/withdrawal programmable
ACCURACY	±0.5%
SYRINGES (MIN./MAX.)	0.5 µl / 1 ml
FLOW RATE:	
Minimum	3.66 pl/min
Maximum	3.82 ml/min
DISPLAY	4.3" WQVGA TFT color display with touchscreen
CONNECTORS:	
RS-485	IEEE-1394, 6 position
USB	Type B
I/O & TTL	15-pin D-Sub Connector
Footswitch	mini phono jack
AVERAGE LINEAR FORCE	5 kg (11 lb) @ 100% force selection
STEP RESOLUTION	0.198 µm/µstep
INPUT POWER	12-30 VDC
INPUT POWER CONNECTION	2.5 mm ID x 5.5 mm OD male plug
POWER SUPPLY	100 to 240 VAC, 50/60 Hz, 18 Watts Universal Power Supply, Use Only a Harvard Apparatus Approved Power Supply and Line Cord
DIMENSIONS, H x W x D:	
Control Box	22.6 x 17.78 x 9.32 cm (9 x 7 x 3.67 in)
Mechanism	6.35 x 5.08 x 19.05 cm (2.5 x 2.0 x 7.5 in)
WEIGHT	1.96 kg (4.32 lb)
REGULATORY CERTIFICATIONS	CE, ETL (UL, CSA), WEEE, EU ROHS & CB Scheme

Order # Product

70-4507	Pump 11 Elite Nanomite Infusion/Withdrawal Programmable Single Syringe
---------	--

PHD ULTRA™



KEY FEATURES

- Superior drive mechanism for unmatched smooth flow, accuracy and precision
- For operation at $\mu\text{l}/\text{min}$ to ml/min flow rates
- Easily program simple to complex methods without a PC
- Alphanumeric keypad for easy Method naming and recall
- Real and relative time clocks
- Intuitive touchscreen and icon interface
- Vertical or horizontal orientation
- Adjustable linear force to 75 lb
- Multi-syringe racks for multi-channel operation or large capacity reservoir
- Legendary reliability – 2 year warranty

APPLICATIONS

- Microfluidics
- Drug/Nutritional Delivery
- Electrospinning
- Reaction Chamber Addition
- Mass Spec Calibration
- Feeding Cells
- Low Pressure Chromatography
- Continuous Flow
- Flow Programming
- Gradients
- % Composition Step Changes
- Large Flow Deliveries
- I/O Interactive Experiments

PHD ULTRA™

The PHD ULTRA™ is the solution for your most demanding fluidics applications. This pump represents the latest technology in syringe pumps and was developed utilizing the feedback of the world's largest population of syringe pump users.

The PHD ULTRA™ will change the way you think about syringe pumps. There are three major reasons the PHD ULTRA™ is the new standard for syringe pumps:

1. **Superior mechanical drive mechanism and syringe holding mechanics to achieve the highest performance of any syringe pump.**
2. **EZ PRO Software and user interface allow easy programming of Methods from simple to complex, all without the use of a PC.**
 - Preprogrammed Methods for simple to complex operations that allow you to be up and running with the touch of a button.
 - LCD, high resolution color touchscreen for powerful functionality, yet very easy to use.
3. **Levels of Versatility**
 - a. **Configurations:** Standard, push-pull, remote, high pressure, multi-racks.
 - b. **Connectivity:** For USB or RS-232 computer control; RS-485 or optional RJ-11 for daisy chain (control multiple pumps).
 - c. **Orientation:** Horizontal or vertical orientation to optimize bench space or to minimize tubing.

PHD ULTRA™ Advanced Syringe Pumps



Highest Accuracy and Precision

The PHD ULTRA™ syringe pump family has a superior fluidics drive mechanism which assures ease of use and high performance, for the smoothest, most accurate flow rates of any syringe pump. Flow rates of 1.50 µl/min to 216.0 ml/min are accurate within 0.25% and reproducible within 0.05%. A microprocessor-controlled, small step angle stepper motor drives a lead screw and pusher block. Advanced micro-stepping techniques are employed to further reduce the step angle to eliminate flow pulsation.

Maximum Experimental Versatility

This pump can be oriented vertically or horizontally for optimum experimental connectivity. This pump comes standard to hold 2 syringes, but can be purchased with 3 other syringe racks: 6/10 syringe rack, 4 x 140 ml syringe rack and 4 x microliter syringe rack. Syringe racks can be ordered separately. Multi-syringe racks provide multi-channel operation or serve as a large capacity reservoir.

Syringe Racks

- The standard 2-syringe rack holds 2 syringes from 0.5 µl to 140 ml
- The 4 x 140 multi-rack holds four 60 ml or 140 ml plastic syringes only
- 6/10 multi-rack will hold up to 10 syringes from 0.5 µl to 20 ml and up to 6 syringes from 30 ml to 60 ml
- The microliter syringe rack independently holds 4 syringes, from 0.5 µl to 10 ml, enabling syringes of different sizes to run simultaneously.

Easy-to-Use Interface

The PHD ULTRA™ Syringe Pumps are very easy to use with an LCD color touchscreen and icon interface. The Message Area of the touchscreen is used to display helpful instructions for the currently displayed screen. It is also used to display error or warning messages to indicate problem conditions in a Method or

error conditions during pump operation. The Run Screen shows all of the pump parameters on one screen for easy review.

Pump Models

The PHD ULTRA™ Pumps are available in three configurations designed for different operating environments and varying degrees of operational flexibility.

Infusion Only: This model supports infusion operations at user-defined flow rates and with selectable target volume or time values to control the total infusion volume. The Infusion Only models do not include programmable, user-defined Methods.

Infusion/Withdrawal: This model supports infuse only, withdraw only, infuse/withdraw and withdraw/infuse operations at user-defined flow rates and with selectable target volume or time. Users can create and store one Method up to 800 steps.

Infusion/Withdrawal Programmable: This model supports infuse only, withdraw only, infuse/withdraw and withdraw/infuse operations. Users can create and store multiple Methods of up to 800 steps on the pump.



PHD ULTRA™ Advanced Syringe Pumps

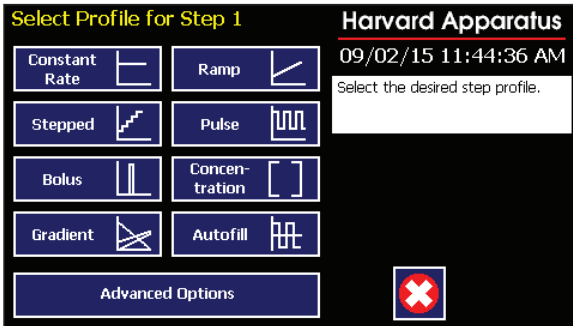

Program Description

To operate the PHD ULTRA™, the user defines all the required parameters for infusing and/or withdrawing liquids through a Method. This may be a Quick Start, Pre-Programmed or User-Defined Method. The basic operation is a simple 3-step procedure:

1. Select a Method
2. Enter operating parameters
3. Preview or Run your Method

Quick Start Methods are for simple infusions, withdrawals or a combination (depending on the pump model). Custom user-defined Methods can be created when a more advanced Method is required. The setup for a custom Method is easy using the standard profiles found on all Infusion/Withdrawal and Infusion/

Constant Rate	Bolus	Pulse
Ramp	Concentration	Autofill
Stepped	Gradient	

By programming and saving custom Methods in the pump, multi-user errors are reduced. Easily transfer complex methods to other pumps and/or download methods from a PC. Forget having to duplicate method-development efforts for each new pump added to your system.

In addition to the advanced pumping profiles listed above, the PHD ULTRA™ contains a variety of advanced options allowing the user to repeat steps, link methods, control valves, external triggers etc.

Advanced Programming Features

Flow Programming: Change the flow with time, volume or a triggered event as many times as you like.

Bolus: Inject a large volume of drug (or drugs) at once. The bolus injection can be made in time or volume.

Concentration Delivery: Calibrate flow in concentration units of mg/kg easily so flow is calibrated to concentration of drug and animal weight.

Gradients: EZ PRO software allows you to easily program gradients, continuous or stepped.

% Ratio: Up to three solvents.

I/O: Dedicated and user defined I/O.

Pulsed Flow: So you can program the pulse easily.

Advanced Connectivity

All PHD ULTRA™ Syringe Pumps come standard with a footswitch, USB, RS-232, RS-485 and I/O connectors. There is also an option for RJ-11 connectors and analog control. These options have to be ordered at the time the pump is ordered.

FOOTSWITCH INPUT	Start and stop a pump
USB AND RS-232 SERIAL INPUTS	Control your pump with a computer
RS-485 CONNECTORS	Connect multiple pumps together (up to 99) Connect remote mechanism Connect satellite pumps to the Master pump for binary or ternary gradient system (% composition)
RJ-11 CONNECTORS (OPTION)	Connect multiple pumps together (daisy chain)
USER I/O CONNECTOR	
Direction Control input	Set pump to infuse or withdraw
Trigger Input	Connect and external device to start or stop a pump or Method
Footswitch Input	Start and stop a pump
Trigger 1 Output	Signal another device to start and stop a pump or Method
Trigger 2 Output	Signal another device to start and stop a pump or Method
Sync Output	Synchronize other devices
Valve Output	External valve control
Run Indicator	Connect an external LED or monitoring device to a pump
ANALOG CONTROL (OPTIONAL)	Analog control of the motor speed (0 to 10 V). This option must be ordered at the same time the pump is ordered.

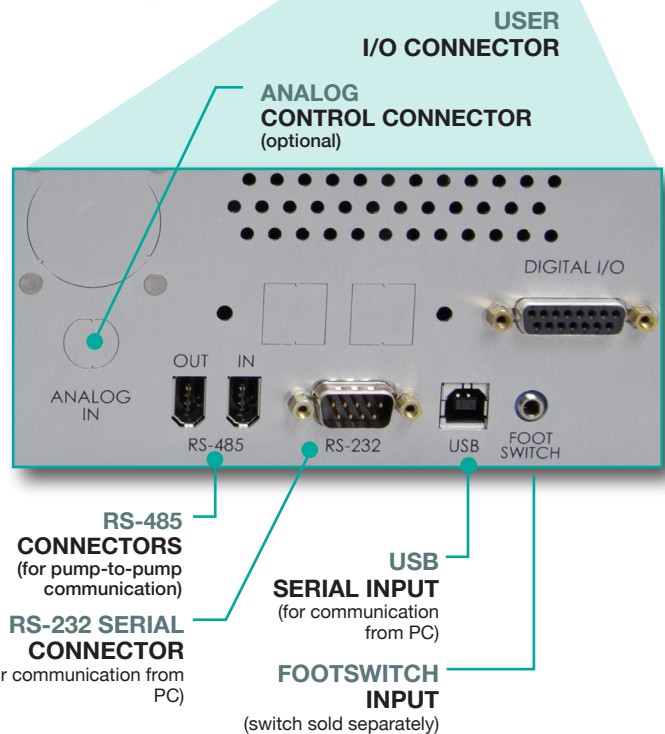
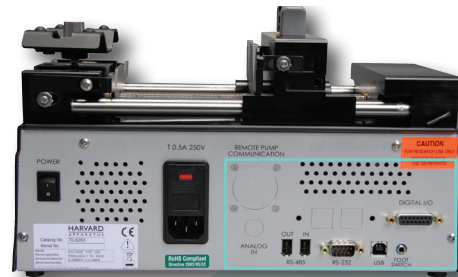

PHD ULTRA™ Advanced Syringe Pumps

Alarms

There are several alarms available on the PHD ULTRA™ Syringe Pumps. **End of Run, Near End of Run, Power Up, Stall, Calibration Reminder**

You may choose to activate one, activate them all or mute them all.

Accessories

A full range of accessories are compatible with the PHD ULTRA™ including syringe heaters, in-line heaters and coolers, microfluidic circuits, connectors, tubing, syringes and more.

For Applications, including Gradient System and GC

PHD ULTRA™ Satellite Pumps

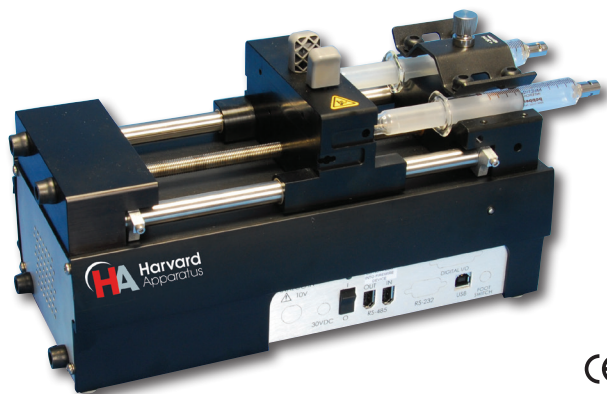

PHD ULTRA™ Satellite Pumps

The Satellite Pumps can be combined with stand alone PHD ULTRA™ Pumps to create a Gradient System or controlled from an HAPC. Satellite Pumps can only be powered from a stand alone PHD ULTRA™ or by the HAPC via RS-485.

PHD ULTRA™ Syringe Pump Modules



PHD ULTRA™ Syringe Pump Modules

The PHD ULTRA™ Syringe Pump Modules are infusion/ withdrawal pumps. They are available in three configurations: standard, push/pull and high force. These modules include a footswitch input, USB, RS-232, RS-485 and I/O connectors. They can be controlled via PC. You can also start and stop a pump using the 15-pin user I/O connector. See Advanced Connectivity on page 21 for more information. See page 34 for more information on Syringe Pump Modules. For use with a PC or an HAPC,

PHD ULTRA™ Advanced Syringe Pumps

PHD ULTRA™ Specifications	
TYPE	Microprocessor multiple syringe, infusion only, infusion/withdrawal or infusion/withdrawal programmable
ACCURACY	±0.25%
SYRINGES:	
Type	Plastic, glass or stainless steel
Size Minimum	0.5 µl
Size Maximum	140 ml
FLOW RATE:	
Minimum	1.50 µl/min
Maximum	216.0 ml/min
DISPLAY	4.3" WQVGA TFT color display with touchscreen
CONNECTORS:	
RS-232	9-pin D-Sub Connector
RS-485	6-position IEEE-1394
USB	Type B
I/O & TTL	15-pin D-Sub Connector
Footswitch	Phono jack
LINEAR FORCE	34 kg (75 lb) @ 100% force selection
STEP RESOLUTION	0.082 µm/µstep
VOLTAGE RANGE	Universal input 100 to 240 VAC, 50/60 Hz
DIMENSIONS, H x W x D	17.8 x 30.48 x 21.59 cm (7 x 12 x 8.5 in)
WEIGHT	4.5 kg (10 lb)
REGULATORY CERTIFICATIONS	CE, ETL (UL, CSA), WEEE, EU RoHS & CB Scheme

Product	Order #	Order #
PHD ULTRA™ Standard	Stand Alone	Satellite*
PHD ULTRA™ Infusion Only	70-3005	-
PHD ULTRA™ Infusion/Withdrawal	-	70-3406
PHD ULTRA™ Infusion/Withdrawal Programmable	70-3007	-
PHD ULTRA™	Stand Alone	Satellite*
PHD ULTRA™ Push/Pull Infusion/Withdrawal	-	70-3408
PHD ULTRA™ Push/Pull Infusion/Withdrawal Programmable	70-3009	-
PHD ULTRA™ High Pressure	Stand Alone	Satellite*
PHD ULTRA™ 4400 Pump I/W Programmable	70-3010	70-3410
PHD ULTRA™ XF Remote I/W Programmable	-	-

Order #	Product
PHD ULTRA™ Options and Kits	
70-3030	RS-232 RJ-11 Connectors Option (daisy chain)
70-3033	Analog Control Input Option (0-10 V) ²
70-3034	Internal Fan Option ³
70-3023	Anti-Siphon Kit for PHD ULTRA™
PHD ULTRA™ Syringe Rack Kits Ordered without a Pump	
70-3024	6/10 Multi-Syringe Rack for PHD ULTRA™, independently holds 10 syringes
70-3021	4 x 140 Multi-Syringe Rack for PHD ULTRA™
70-3022	Microliter Rack for PHD ULTRA™, independently holds 4 syringes
PHD ULTRA™ Syringe Rack Kits Ordered with a Pump	
70-3024A	6/10 Multi-Syringe Rack for PHD ULTRA™, independently holds 10 syringes
70-3021A	4 x 140 Multi-Syringe Rack for PHD ULTRA™
70-3022A	Microliter Rack for PHD ULTRA™, independently holds 4 syringes
PHD ULTRA™ Upgrades	
70-4011	Upgrade Infusion Only to Programmable ¹
70-4012	Upgrade I/W to Programmable ¹

¹ Note: Requires Return to Factory

² Note: Only for Programmable Models. Not available on Satellite Boxes.

³ Note: Fan option is required if external operating ambient is expected to be >35°C

Accessories	
70-4000	RS-485 Cable for Pump-to-Pump Communication, 0.5 m (1.6 ft)
70-4001	RS-485 Cable for Pump-to-Pump Communication, 2 m (6.6 ft)
70-4020	RS-485 Extension Cable, 9.1 m (30 ft)
70-4021	RS-485 Extension Cable, 1 m (3.2 ft)
70-4002	USB Cable for PC-to-Pump Communication, 2 m (6.6 ft)
70-4003	USB Cable for PC-to-Pump Communication, 5 m (16.4 ft)
70-4004	RS-232 Cable for PC-to-Pump Communication, 9-pin D-sub, 2 m (6.6 ft)
70-4006	Adapter, D-sub 15 to Term. Blk
72-8340	Adapter, USB to Serial
70-2215	Footswitch (with Phono Plug)
55-7013	Continuous flow valve box, 100 psi
55-7760	Cable Assy, Daisy-chain, Legacy RS-232 RJ-11, 0.6 m (2 ft)
55-8000	Plunger Adapter for 25 ml, 50 ml, 100 ml Hamilton GasTight™ Syringes

PHD ULTRA™ Push/Pull Syringe Pump

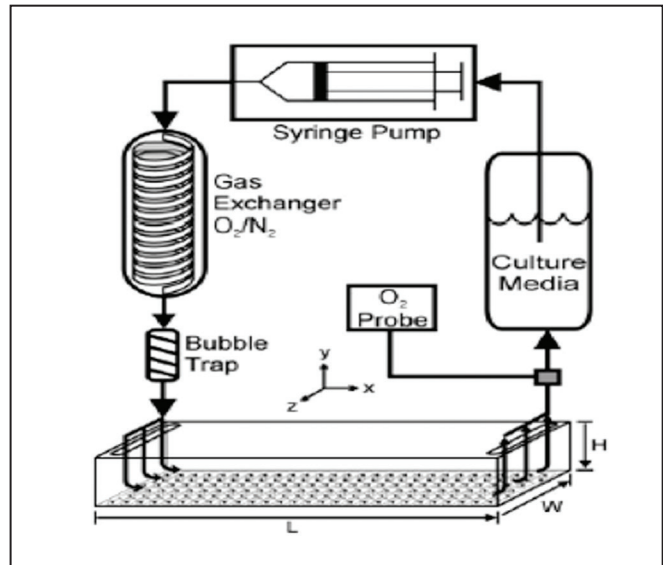

Pressure-driven flow was continuous using a programmable push-pull syringe pump (Harvard Apparatus, Holliston, MA). Media was equilibrated with 10% or 21% O₂ in a gas exchanger made with gas-permeable silastic tubing¹.

- **Compensating Flows:** The control of continuous infusion and simultaneous withdrawal of liquids while monitoring fluid levels
- **Perfusion Across Tissue Beds:** Directional control of flows across tissue beds using switching valves
- **Continuous Flow with High Accuracy and Smooth Flow:** Pump Any Volume Large or Small with Smooth, Non Pulsating Flow
- **Continuous Accurate Flow for High Pressure Systems:** Unlike peristaltic pumps, syringe pumps can pump against high pressures

The PHD ULTRA™ Push-Pull syringe pump provides virtually pulse free, high accuracy and high precision flow. Complex programs can be written using on-board EZ Pro software to reduce shear stress during cell deposition and adhesion during tissue and organ development. Conversely, the same complex programs can be used to create particular shear forces on developing cells.

The PHD ULTRA™ Push Pull combines the high accuracy of our ULTRA line of pumps. Harvard Apparatus also has a wide array of temperature control products to provide complete environmental control. Our 2 year warranty and robust construction allow these pumps to work continuously for extended periods of time with unsurpassed reliability.

Order #	Product
70-3009	PHD ULTRA™ Push-Pull Programmable Syringe Pump
61-0270	Continuous Flow Tubing Segment
55-7013	Valve Box, Medium Pressure

*Note: For full product offering please see page 23.

PHD ULTRA™ CP Constant Pressure Syringe Pump

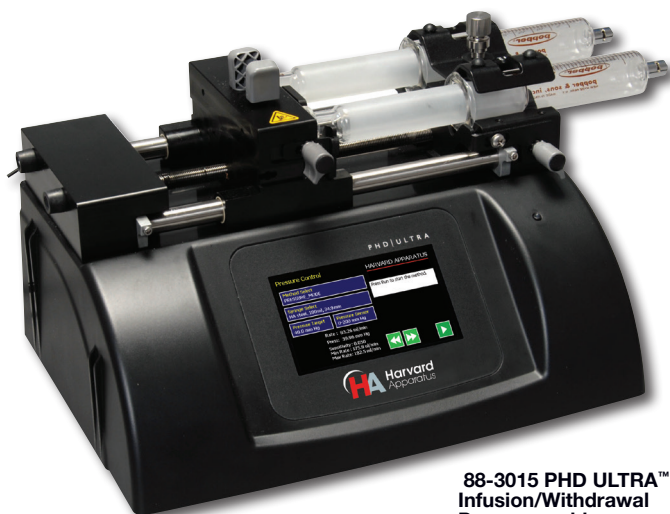

88-3015 PHD ULTRA™ CP Infusion/Withdrawal Programmable

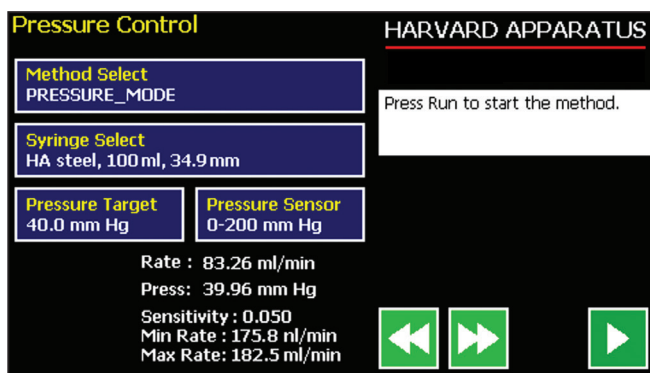

Our user-friendly touchscreen interface allows for simple control of either constant pressure or constant flow-based applications.

KEY FEATURES

- Enables continuous pressure-controlled infusion
- Use in constant flow or constant pressure mode
- Enhances safety for sensitive infusion targets and physiological experimentation
- Compatible with a wide range of pressure transducers
- Automatically adjusts flow rate to maintain constant pressure
- PC Datalog Application with real-time parameter plotting

APPLICATIONS

- Short-term organ perfusion studies that require the maintenance of physiologic conditions
- Introduction of chemical reactants in a controlled manner
- Ocular injections and perfusions
- Small animal whole-body perfusions
- Constant pressure microfluidic mixing

Constant Pressure Syringe Pump Technology Breakthrough

The PHD ULTRA™ CP Syringe Pump is the first of its kind to allow operation under constant pressure or constant flow. Historically, the only means available to dispense at constant pressure has involved the use of various amplifiers and other accessories/software. The PHD ULTRA™ CP Syringe Pump, when combined with virtually any commercially available pressure transducer/amplifier combination with 0-10 V DC analog output, results in a constant pressure dispensing system. This system can deliver fluids with an applied force up to 1,000 lb (depending upon the pump).

Superior Functionality

Using Harvard Apparatus syringe pump technology and software controlled pressure monitoring, the PHD ULTRA™ CP Syringe Pump is able to maintain a user-defined system pressure $\pm 2\%$ once the steady state pressure value has been achieved.

A user-adjustable sensitivity setting allows for the customization of the system response time necessary to attain the set pressure. The PHD ULTRA™ CP Syringe Pump allows the user to set pressures in the units of their choice including mmHg, kPa, and psi.

Pressure & Flow Rate Data

Data can be monitored via RS-232 from the PHD ULTRA™ CP Syringe Pump to a PC. In practice, the 0-10 V analog output of a pressure transducer amplifier is connected to the analog input on the rear panel of the pump. The amplifier or signal conditioner can be provided by the customer, or accomplished with various transducers and amplifiers available from Harvard Apparatus, see pages 42 to 45. The pressure range may be scaled to fit the available transducer voltage output for systems that output less than 10 V. While in constant pressure mode, in addition to the set and actual pressure, the pump displays the flow rate. This data may be output for further analysis with a variety of data acquisition packages.

Accuracy & Reproducibility

In addition to constant pressure mode, the PHD ULTRA™ CP Syringe Pump may also be used in flow mode with its world renowned accuracy and reproducibility.

All PHD ULTRA™ CP Syringe Pumps are infusion/withdrawal programmable models. When used in flow mode, these offer programmable features such as method storage and flow programming functions to allow the user to create simple to complex methods (see page 19). The PHD ULTRA™ CP Syringe Pump is available in a variety of configurations to suit the desired pressure or flow rate ranges.

PHD ULTRA™ CP Constant Pressure Syringe Pump

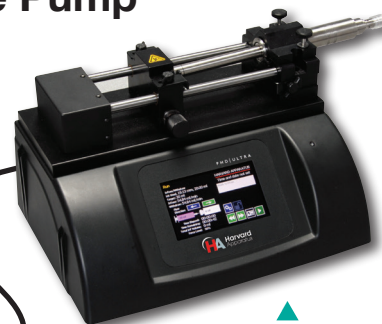
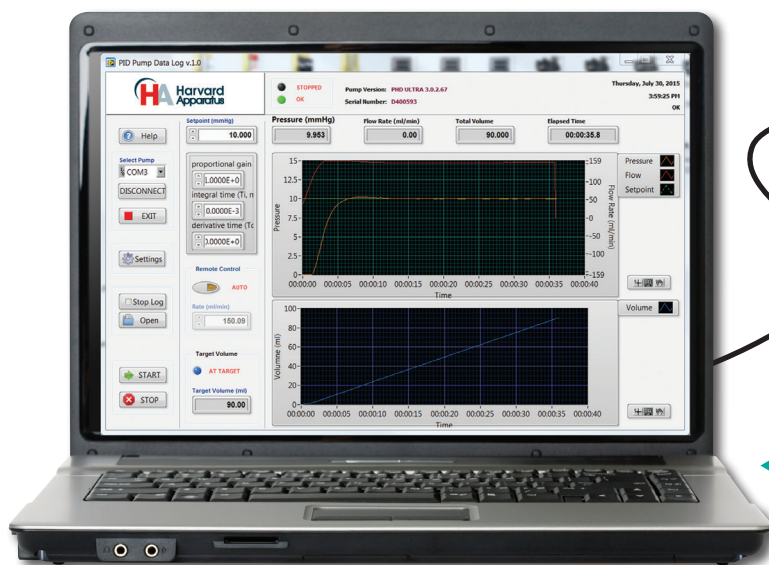

88-3016 PHD ULTRA™ CP 4400 Infusion/Withdrawal Programmable

A screen shot of the Harvard Apparatus Constant Pressure Monitoring Software*.

Specifications	PHD ULTRA™ CP	PHD ULTRA™ CP 4400
TYPE	Microprocessor, multiple syringe, infusion/withdrawal, programmable	Microprocessor, multiple syringe, infusion/withdrawal, programmable
FLOW ACCURACY	±0.25%	±0.35%
PRESSURE ACCURACY	< ±2%	< ±2%
SYRINGE SIZE, MIX/MAX	0.5 µl to 140 ml	0.5 µl to 140 ml
# SYRINGES	2-10	1
FLOW RATE:		
MINIMUM	1.50 pl/min	3.06 pl/min
MAXIMUM	216.0 ml/min	216.0 ml/min
CONNECTORS:		
USB (PC-to-Pump)	Type B	Type B
RS-232 (PC-to-Pump)	9-pin D-Sub	9-pin D-Sub
RS-485* (Pump-to-Pump)	IEEE-1394, 6 pos	IEEE-1394, 6 pos
I/O & TTL	15-pin D-Sub	15-pin D-Sub
AVERAGE LINEAR FORCE	34 kg (75 lb) at 100%	91 kg (200 lb) at 100%
MAXIMUM PRESSURE (with 100 ml Syringe)	50 psi	135 psi
DIMENSIONS CONTROL BOX	30.5 x 21.6 x 17.8 cm (12 x 8.5 x 7 in)	30.5 x 21.6 x 10.6 cm (12 x 8.5 x 4.3 in)
WEIGHT	4.5 kg (10 lb)	5.4 kg (12 lb)
VOLTAGE RANGE	100 to 240 VAC; 50/60 Hz	100 to 240 VAC; 50/60 Hz
Order #	88-3015	88-3016

*Note: PC laptop not included.

KEY FEATURES

- Enables continuous pressure-controlled infusion
- Use in constant flow or constant pressure mode
- Enhances safety for sensitive infusion targets and physiological experimentation
- Compatible with a wide range of pressure transducers
- Automatically adjusts flow rate to maintain constant pressure
- Alpha/numeric keyboard without a PC
- Icon operation
- New color LCD touchscreen
- Up-front control knobs for ease of operation
- Vertical or horizontal orientation
- Adjustable linear force to 75 lb across the entire flow range
- PC Application Included (For datalogging and PC control if required)
- CE, ETL (UL, CSA), WEEE, EU RoHS & CB Scheme Approved
- 2 year warranty

APPLICATIONS

- Short-term organ perfusion studies that require the maintenance of physiologic conditions.
- Introduction of chemical reactants in a controlled manner.
- Ocular injections and perfusions.
- Small animal whole-body perfusions.
- Constant pressure microfluidic mixing.
- Administration of genetic material into organs without viral vectors.

PHD ULTRA™ 4400



PHD ULTRA™ 4400 Stand-Alone

KEY FEATURES

- Delivers >200 lb (91 kg) linear pumping force across a wide flow rate range
- Accurate and smooth flow
- Ideally suited for stainless steel syringes
- Easy-to-use touchscreen and icon interface
- Program simple to complex Methods without a PC

APPLICATIONS

- High Pressure Injections
- Drug Delivery
- Pumping Highly Corrosive Fluids
- Injecting into High Pressure Reaction Vessels
- Remote pumping of Hazardous Material

The PHD ULTRA™ 4400 is a single syringe infusion/withdrawal programmable syringe pump. This pump allows you to create, save and run simple to complex Methods without a PC or just enter a flow rate and run. The flow rate range is 3.06 pl/min to 216.0 ml/min with 200 lb of adjustable force across the entire flow rate range. For more information on the PHD ULTRA™ 4400 including features and programming see page 26.

The PHD ULTRA™ 4400 pump is ideal for high pressure applications. This pump is available in two configurations: stand-alone and remote. The remote model consists of a control unit, a syringe pumping mechanism and a 5 foot cable to connect the two units.

The PHD ULTRA™ 4400 has a footswitch input, RS-232 and USB serial ports for computer control, RS-485 ports for daisy chaining pumps and Digital I/O for external control via an independent computer or device. There is also an option for daisy chaining pumps through the RS-232 (RJ-11) ports. This option must be ordered at the time the pump is ordered.

Specifications		PHD ULTRA™ 4400 Stand-Alone
TYPE		Microprocessor single syringe infusion/withdrawal programmable
ACCURACY		±0.35%
SYRINGES		
Type		Glass, Plastic or Stainless Steel
Size Minimum		0.5 µl
Size Maximum		140 ml
FLOW RATE:		
Minimum		3.06 pl/min
Maximum		216.0 ml/min
DISPLAY		4.3" WQVGA TFT color display with touchscreen
CONNECTORS:		
RS-232		9-pin D-Sub Connector
RS-485		IEEE-1394, 6 pos
USB		Type B
I/O & TTL		15-pin D-Sub Connector
Footswitch		Phono jack
AVERAGE LINEAR FORCE		91 kg (200 lb) @ 100% Force Selection
STEP RESOLUTION		0.164 µm/µstep
VOLTAGE RANGE		Universal input 100 to 240 VAC, 50/60 Hz, 50 W, 0.5 A fuse
DIMENSIONS, H x W x D:		
Control Box		30.48 x 21.59 x 18.4 cm (12 x 8.5 x 7.25 in)
Remote Box		N/A
WEIGHT		5.5 kg (12.1 lb)
REGULATORY CERTIFICATIONS		CE, ETL (UL, CSA), WEEE, EU RoHS and CB Scheme
Order #		70-3010

Accessories	
70-4000	RS-485 Cable for Pump-to-Pump Communication, 0.5 m (1.6 ft)
70-4021	RS-485 Cable for Pump-to-Pump Communication, 1 m (3.3 ft)
70-4001	RS-485 Cable for Pump-to-Pump Communication, 2 m (6.6 ft)
70-4002	USB Cable for PC-to-Pump Communication, 2 m (6.6 ft)
70-4003	USB Cable for PC-to-Pump Communication, 5 m (16.4 ft)
70-4004	RS-232 Cable for PC-to-Pump Communication, 9-pin D-sub, 2 m (6.6 ft)
70-4020	RS-485 Cable (IEEE-1394) Remote Extension Cable, 9.1 m (30 ft)
72-4006	Adapter, D-sub 15 to Term, Blk
70-3315	Footswitch (with Phono Plug)
55-7760	Cable Assy, Daisy-chain, Legacy RS-232 RJ-11, 0.6 m (2 ft)

Harvard Apparatus Pump Controller



Precision infusion for accurate, reliable and repeatable results is critical to the success of your work. High experiment throughput is essential to keep up with your rapidly changing research area.

What if you had a pump controller that would allow you to run multiple infusion experiments—simultaneously or independently, to accelerate experiment throughput without compromising accuracy? And what if that tool provided clear feedback on each experiment—in real time?

Compatible with Harvard Apparatus Nanomite, PHD ULTRA™ and Pump 11 Elite/ Pico Plus Elite stand-alone syringe pumps and syringe pump modules, the controller is easy to set up and easy to use.

KEY FEATURES

- Run Multiple Experiments Simultaneously to Increase Laboratory Efficiency
- Modular System – Field Expandable
- Large Color Touch Screen Control with Intuitive Graphical User Interface
- Controls High Precision Harvard Apparatus Syringe Pumps

BENEFITS

- Powerful—Control up to four Harvard Apparatus Nanomites, Pump 11 Elite/Pico and/or PHD ULTRA™ syringe pump modules or stand-alone touch screen pumps
- Flexible—Deploy four of the same or four different channel modules, simultaneously or independently
- Scalable—Easily add channel modules as your research needs grow
- Efficient—Run multiple experiments simultaneously for increased lab throughput
- User Friendly—Innovative, intuitive Graphical User Interface for clear setup & run feedback and to easily create & save pump profiles
- Full Method Programmability—compatible with the entire PHD ULTRA™ Method suite

Expandable, Modular System

Add additional channels when you're ready.



Intuitive User Interface

The intuitive Harvard Apparatus Pump Controller graphical user interface controlled with a large 7" LCD color touch screen display allows quick and easy setup for each channel.

Select the infuse method, syringe type, flow rates and target with the touch of a finger.

The HAPC application software provides convenient selection of common syringe models from a syringe select table, as well as insertion of custom syringe specifications.

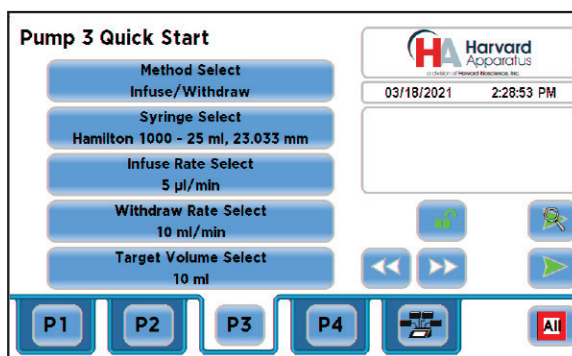

CONTROLLER SPECIFICATIONS				
Catalog Number	704401	704402	704403	704404
Channels	1	2	3	4
Display	7" WQVGA TFT Color Display with Touch Screen			
Mode of Operation	Continuous with Method and conditional syringe pump control features			
Non-Volatile Memory	Stores all settings			
Connectors:				
RS-485	IEEE-1394, 6 pos			
USB	Type B			
I/O & TTL	15 pin D-Sub connector, per channel			
Footswitch	Mini phono jack (one per channel)			
8-Pin Phoenix	For channel connection to Nanomite Module			
Voltage Range	100-240 VAC, 50/60 Hz			
Dimensions (L X W X H)	8.75 x 10 x 6.25 in (22 x 25.4 x 15.87 cm)			
Weight (populated with four channels)	2.3 kg (5 lbs)			
Atmospheric Conditions				
Operating Temperature	4°C to 40°C (40°F to 104°F)			
Storage Temperature	-10°C to 70°C (14°F to 158°F)			
Storage Humidity	20% to 80% RH, non condensing			
Power	100 to 240 VAC, 50/60 Hz 50 W, 0.5 A fuse			
Classification	Class I			
Pollution Degree	1			
Installation Category	II			
Regulatory Certifications	CE, ETL (UL, CSA), WEEE, EU RoHS & CB Scheme			
Safety Declarations	ANSI/UL 61010-1; CAN/CSA C22.2 No. 61010-1; IEC 61010-1; CB Scheme			
EMC Declaration	FCC 47CFR 15B; EN61326-1			

MODULE SPECIFICATIONS						
	Nanomite Injector	Pump 11 Elite Syringe Pump Module	Pump 11 Pico Plus Elite Syringe Pump Module	PHD ULTRA™ Satellite Syringe Pump	PHD ULTRA™ 4400 Satellite Syringe Pump	PHD ULTRA™ XF Syringe Pump Module
Catalog Number	703602 (Single)	704804 (Single) 704805 (Dual)	704806 (Dual) 704807 (Single)	703406 (Dual) 703408 (Dual Push/Pull)	703410 (Single)	703514 (Four Syringe)
Accuracy	±0.5%	±0.5%	± 0.35%	± 0.25%	± 0.35%	± 0.5%
Syringe (Min./Max.)	0.5 µl / 1 ml	0.5 µl / 60 ml (10 ml dual)	0.5 ul - 10 ml (Dual) / 60 ml (Single)	0.5 µl / 140 ml	0.5 µl / 140 ml	20 ml / 200 ml
Minimum Flow Rate	3.66 pl/min	1.26 pl/min (0.5 µl syringe)	0.54 pl/min (0.5 µl syringe)	3.16 pl/min (0.5 µl syringe)	3.16 pl/min (0.5 µl syringe)	50.7 nl/min (20 ml syringe)
Maximum Flow Rate:	3.82 ml/min (1 ml syringe)	88.40 ml/min (26.02 ml/min dual)	11.7 ml/min (Dual), 39.7 ml/min (Single)	215.8 ml/min (140 ml syringe)	215.8 ml/min (140 ml syringe)	144.08 ml/min (200 ml syringe)
Display	none	none	none	none	none	none
Linear Force(Max) @ 100% force selection	5 kg (11 lbs)	16 kg (35 lbs)	16 kg (35 lbs)	34 kg (75 lb)	91 kg (200 lb)	455 kg (1000 lb)
Dimensions (L X W X H)	2.5 x 2.0 x 7.5 in (6.35 x 5.08 x 19.05) cm	24.13 x 17.15 x 10.67 cm (9.5 x 6.75 x 4.2 in)	24.13 x 17.15 x 10.67 cm (9.5 x 6.75 x 4.2 in)	11.75 x 5.5 x 6.5 in (29.8 x 14.0 x 16.5 cm)	11.75 x 5.5 x 6.5 in (29.8 x 14.0 x 16.5 cm)	16 x 12 x 8.5 in (40.64 x 30.48 x 21.6 cm)
Weight (injector/module only)	0.54kg (1.2 lb)	2.3 kg (5.08 lbs)	2.3 kg (5.08 lbs)	5.1 kg (11.2 lb)	5.3 kg (11.7 lb)	20 kg (44 lb)

Note: The Pump 11 Elite, Pico Plus Elite and PHD ULTRA™ XF are fully PC controllable and come with external power supplies. When used with the HAPC, the power supplies are not required. In cases of extremely high pressure applications using the PHD ULTRA™ XF, the external power supplier may be required. Please contact Technical Support for additional application questions.

Harvard Apparatus Pump Controller (continued)

ORDERING INFORMATION	
Catalog #	Description
Harvard Apparatus Pump Controller (HAPC)	
704400	HAPC-M: 1 Channel Module Upgrade, no controller.
704401	HAPC-1: Controller populated with one channel module.
704402	HAPC-2: Controller populated with two channel modules.
704403	HAPC-3: Controller populated with three channel modules.
704404	HAPC-4: Controller populated with four channel modules.
Pump Modules*	
703602	Nanomite Injector, Single Syringe
704804	Pump 11 Elite Single Syringe Pump Module
704805	Pump 11 Elite Dual Syringe Pump Module
704806	Pump 11 Pico Plus Elite Dual Syringe Pump Module
704807	Pump 11 Pico Plus Elite Single Syringe Pump Module
703406	PHD ULTRA™ Satellite Syringe Pump Module
703408	PHD ULTRA™ Push/Pull Satellite Module
703410	PHD ULTRA™ 4400 Satellite Module
703514	PHD ULTRA™ XF Syringe Pump Module
Accessories	
702215	Footswitch (with Phono Plug)
704405	HAPC-B: Controller Blank Panel
704021	RS-485 Cable, HAPC Channel to pump, 1 m (3.3 ft)
704001	RS-485 Cable, HAPC Channel to pump, 2 m (6.6 ft)
704020	RS-485 Cable, HAPC Channel to pump 9 m (29 ft)

Syringe Pump Solutions for System Integrators – Pump Modules and Open Baseplate configurations

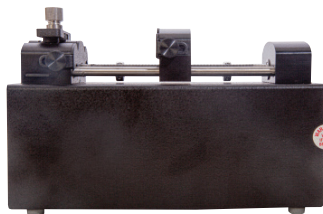

Pump 11 Elite/Pico Plus Elite Module

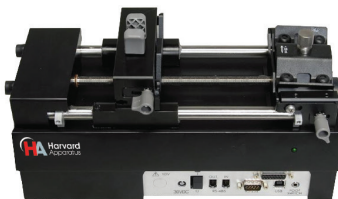

PHD ULTRA™ Syringe Pump Module

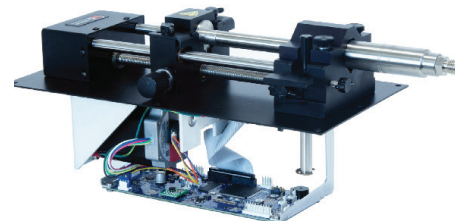

PHD ULTRA™ 4400 Open Baseplate

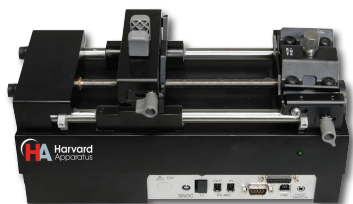

PHD ULTRA™ Syringe Pump Module

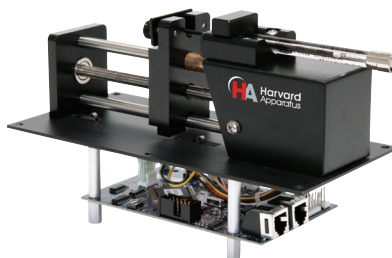

Microliter Syringe Pump Baseplate Mount



PHD ULTRA™ High Force Syringe Pump,

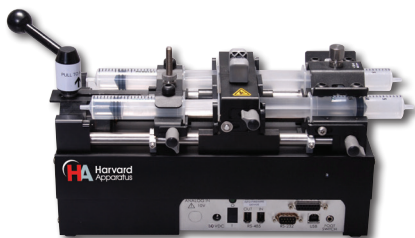

PHD ULTRA™ Push/Pull Syringe Pump Module

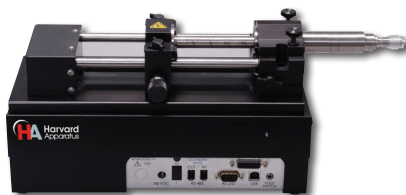

PHD ULTRA™ 4400 Syringe Pump Module

Harvard Apparatus has a wealth of experience in the development and manufacture of specialized fluidic systems. With a full line of modular pumps and open baseplate designs, we offer the broadest selection of fluidics components, systems and specials. We can readily customize to best meet your application needs. Cited in thousands of studies across a myriad of applications, Harvard Apparatus pumps are best-in-class.

All of the Harvard Apparatus Pump Modules and Open Baseplate configurations are based upon our proven digital syringe pumps. They deliver the same accuracy and reproducibility as our stand alone pumps.

All of our products for System Integration require 12-30VDC input and have multiple options for system control.

APPLICATIONS:

- Mass Spectrometer Calibration Systems
- Medical Injection Devices
- Microfluidic Systems
- Drug Deposition Systems
- Electrospinning

PUMP 33 DDS



Pump 33 DDS

KEY FEATURES

- Two independently controlled syringe pumps in one instrument
- High Accuracy $\pm 0.25\%$
- Accommodates syringe sizes 0.5 μ l to 60 ml
- Smooth flow down to 1.02 pl/min (syringe dependent)

The Harvard Apparatus Pump 33 DDS (Dual Drive System) is a leap forward in syringe pump capability. The Pump 33 DDS has two independent pumping channels controlled by an intuitive touchscreen interface.

Graphical User Interface

The intuitive Pump 33 DDS graphical user interface controlled with a large 7" LCD color touchscreen display allows quick and easy setup. The display run screen presents the user with all key dispensing parameters in real time. Syringe tables containing all major syringe manufacturers allow simple selection of any compatible syringe size. Audible Alarms, Adjustable Force and Screen Lock are all features that are available with a touch of the screen.

Advanced Connectivity

The Pump 33 DDS comes standard with USB and RS-232 for PC communication and RS-485 for pump-to-pump communication. An entire suite of ASCII commands is available to control the pump remotely with a PC. The pump contains a footswitch input

Current Operating Condition

Mode Status, Syringe Size/Type, Dispense Time and Volume, Flow Rates and Force Settings

Real-Time Graphical Syringe Status Channel 2

Independent Run 05/19/2016 10:56:00 AM Harvard Apparatus

Notice: Volume Target has been reached.

Inf/WD	STATUS	WD/Inf (Cycle)
Hamilton 700 500 µl	SYRINGE	Hamilton 1000 50 ml
60 sec	TIME ELAPSED	44.03 sec
---	TIME LEFT	---

Real-Time Graphical Syringe Status Channel 1

Run/Stop Channel 1

Reset Counters Channel 1

Return to Condition Selection Screen

System Settings

Screen Lock/Unlock

Fast Forward/Fast Reverse

Run/Stop Channel 2

Run/Stop Channels 1 and 2

Reset Counters Channel 2

Select Syringe 05/04/2016 14:40:40 Harvard Apparatus

P1

Custom Syringe	Gang x1	Syringe Size Selection	
Air-Tite	PAGE	5 ml, 11.989 mm	PAGE
HSW Norm-Ject	↑	10 ml, 14.427 mm	↑
Becton Dickinson Glass	LINE	20 ml, 19.05 mm	LINE
Becton Dickinson Plasti-pak	↑	30 ml, 21.59 mm	LINE
Cadence Science Micro-Mate Glass	LINE	50 ml, 26.594 mm	LINE
CMA Microdialysis	↓	60 ml, 26.594 mm	PAGE
Hamilton 700 Glass	PAGE		

Pump 33 DDS Syringe Selection Screen

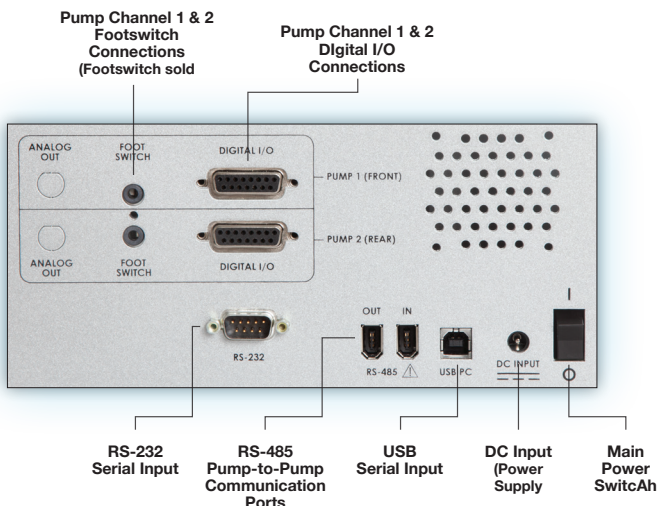

HarvardApparatussyringepumpsareforresearchpurposesonly.Notforuseonhumans.

PUMP 33 DDS

Operating Conditions

Three operating conditions are available to accommodate a wide range of setups and experimental protocols.

Independent Condition

Independent Condition allows the Pump 33 DDS to operate as two separate syringe pumps named P1 & P2. Each syringe will operate independently with different syringe types, size, force, target (volume or time, mode dependent).

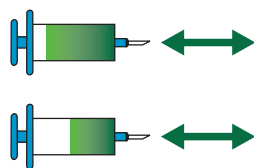

	Mode	Syringe	Rate	Target Volume/Time
P1	Infuse, Withdraw, Infuse/Withdraw, Withdraw/Infuse	Any size/type 0.5 µl -60 ml	Any within syringe capability	Any (Mode Dependent)
P2	Infuse, Withdraw, Infuse/Withdraw, Withdraw/Infuse	Any size/type 0.5 µl -60 ml	Any within syringe capability	Same as P1

Reciprocating Condition

In reciprocating condition, both syringe channels move in opposite directions at the same rate using the same syringe size and type. When combined with a valve box, the reciprocating condition can provide the continuous fluidic delivery of a peristaltic pump with the accurate, low flow rates provided by a syringe pump.

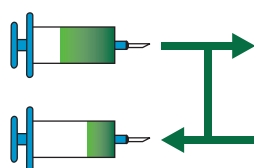

	Mode	Syringe	Rate	Target Volume/Time
P1	Infuse/Withdraw, Withdraw/Infuse	Any size/type 0.5 µl -60 ml	Any within syringe capability	Any
P2	Opposite of P1	Same as P1	Same as P1	Same as P1

Twin Condition

Twin Condition allows both syringes to operate in the same mode using the exact same syringe type, syringe size, force, target (volume or time) and flow rate settings. The pump also allows the user to combine both flows for higher speed and volume infusion applications.

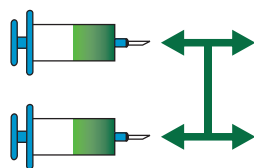

	Mode	Syringe	Rate	Target Volume/Time
P1	Infuse, Withdraw, Infuse/Withdraw, Withdraw/Infuse	Any size/type 0.5 µl -60 ml	Any within syringe capability	Any (Mode Dependent)
P2	Same as P1	Same as P1	Same as P1	Same as P1

Specifications	
Type	Microprocessor dual infuse/withdraw/continuous syringe pump
Accuracy	±0.25%
Syringe:	
Type	Glass, plastic and stainless steel
Size Minimum	0.5 µl (0.103 mm minimum inner diameter)
Size Maximum	60 ml (32.573 mm maximum inner diameter)*
Flow Rate:	
Minimum	1.02 µl/min (0.5 µl syringe, 0.103 mm inner diameter)
Maximum	106 ml/min (60 ml syringe, 32.573 mm diameter)
Display	7" color display with touchscreen
Connectors:	
USB	Type B
RS-232	9-pin D-sub connector
RS-485	IEEE-1394, 6 pos for pump-pump communication

TTL Input/Output	Two 15-pin D-sub connectors, one for each pump mechanism
Footswitch	Two phonojack inputs, one for each pump mechanism
Average Linear Force	70 lb (31.75 kg) at 100% force setting up to a flow rate of 90 ml/min using up to a 60 ml syringe with a 32.573 mm inner diameter 50 lb (22.6 kg) at 100% force setting for flow rates 90 ml/min to 106 ml/min using the same size syringe
Power Supply	Input 100 to 240 VAC, 50/60 Hz, Output 30 V 1.66 A 50 W
Weight	21 lb (9.09 kg)
Dimensions (L x D x H)	11 x 15 x 8" (28 x 39 x 21 cm)
Classification	Class I
Pollution	Degree 1
Installation	Category II

Order #	Product
70-3333	Pump 33 DDS Dual Independent Syringe Pump
70-2215	Footswitch (with phone plug)
55-7013	Valve box

FlowControl™ Software

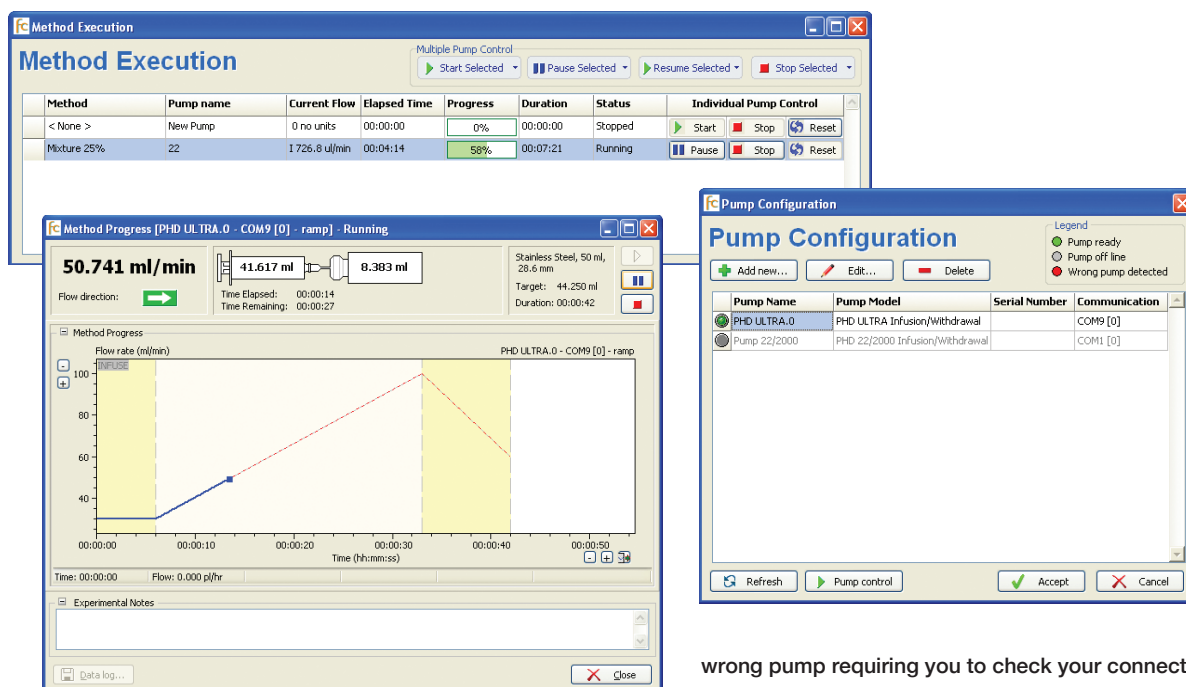

wrong pump requiring you to check your connection.

KEY FEATURES

- Single or multiple pump control
- Easily create simple Methods or more advanced multi-step Methods
- Run multiple pumps in a chain or via USB hub
- Displays all of the pump operating parameters
- Control the same or different pump models
- Graphically track pump progress
- Printable data log

FlowControl™ is an easy to use software program that is run on your PC. It is designed to work with key Harvard Apparatus Syringe Pumps that have an RS-232 or USB serial input including: PHD ULTRA™ Series and Pump 11 Elite Series of pumps.

Single or Multiple Pump Control

FlowControl™ has the ability to control single or multiple pumps. Multiple pumps are controlled in a daisy chain or via USB hub. The number of pumps allowed in a daisy chain is dependent upon the model.

Individual syringe pumps can be controlled by entering syringe data, flow rate and choosing a flow direction (infusion or withdrawal). Flow rate and flow direction can be changed while the pump is running.

FlowControl™ allows you to create, review, edit, save, recall and download Methods. You can create simple to complex Methods to control one or more pumps individually or simultaneously.

Pump Status

The pump configuration screen tells you the status of all defined pumps. If the light is green, the pump is ready. If the light is gray the pump is off line. If the light is red the software is detecting the

Pump Graph

In addition to the run time execution information in the Method Execution window, FlowControl™ allows you to graphically monitor the real flow progress of each independent pump in the Method Progress window. The Method Progress screen displays all of the pumping parameters for the individual pump in an easy to read format. This allows you to monitor infuse and refill rates and volume dispensed.

Data Log

FlowControl™ creates a data log that tracks the activity of your pump based on a specific Method. When a data log is created three different files are generated with the same name but different extensions; excel report (*.xls), bitmap report (*.bmp) and experimental notes (*.txt). The bitmap report shows a screen shot of the pump flow evolution chart from the Method Progress

FlowControl™ Specifications

COMPUTER REQUIREMENTS	1GHz Pentium® processor or higher, 512 MB of RAM (1 GB recommended)
SYSTEM REQUIREMENTS	Windows 10/7/XP

Order # Product

70-6000	FlowControl™ Software
---------	-----------------------

Continuous Delivery Valve Box



55-7013 Continuous Delivery Valve Box

The Continuous Delivery Valve Box has two valves mounted and is used with our PHD ULTRA push/pull and Pump 33 DDS syringe pumps.

The Continuous Delivery Valve Box for medium pressure is supplied with 3-port valves containing 1/4-28 thread with 1.6 mm

Order #	Product
55-7013	Continuous Delivery Valve Box, Medium Pressure, 100 psi

RS-232 and RJ-11 Daisy Chain Cables

The 70-2022 RS-232 Connection Cable is for use with all Harvard Apparatus Syringe Pumps except for the Pump 22 and the PHD ULTRA™. The 70-4004 RS-232 Connection Cable is for use with the PHD ULTRA™ Syringe Pumps.

The 55-7760 and 72-2478 Daisy Chain Cables are for use with all Harvard Apparatus Syringe Pumps except for the PHD ULTRA™ without the legacy RS-232 (RJ-11 ports).

The PHD ULTRA™ daisy chain via RS-485 instead of RS-232. When controlling a syringe pump using a computer, a single RS-232 cable is required to connect the computer to the pump. If multiple pumps are being controlled by one computer then one Daisy Chain Cable is required for each additional pump.

Order #	Product
70-2022	RS-232 Connection Cable, 7 ft, 9-pin D-Sub/RJ11 for Pump 11 Elite w/ RS232 card
70-4004	RS-232 Connection Cable, 6 ft, 9-pin D-Sub/D-Sub for PhD Ultra
55-7760	Daisy Chain Cable, (2 ft) Need 1 Per Pump RJ-11

Pressure Transducers for PHD ULTRA CP Syringe Pump

HSE Multi Sensor Amplifier



The HSE Multi Sensor Amplifier is designed for measurement applications in general laboratory or light industrial applications for amplification of sensor signals from pressure, force, displacement or other transducers.

It is equipped with three measurement ranges for optimal performance. It is factory calibrated to an HSE sensor (transducer) ordered at the same time.

- Three measurement range settings. These can be used for low, mid and high measurement ranges for one specific sensor. Or you can use three different sensors without the need to change gain settings as long as there are no jumper changes needed.
- Internally pre-set gain for each range, eliminating the possibility of unintended gain change leading to issues comparing repeating measurement
- Zero adjustment over full measurement range
- Bright display of measurement values, adjustable contrast
- Analog output ± 5 V for range maximum
- Output voltage adjustment for analog output signals

Order #	Product
73-5078	HSE Multi Sensor Amplifier, for HSE Sensors
73-4479	Manual Pressure Calibrator, Range 0-300 mm Hg

APT300 Blood Pressure Transducer

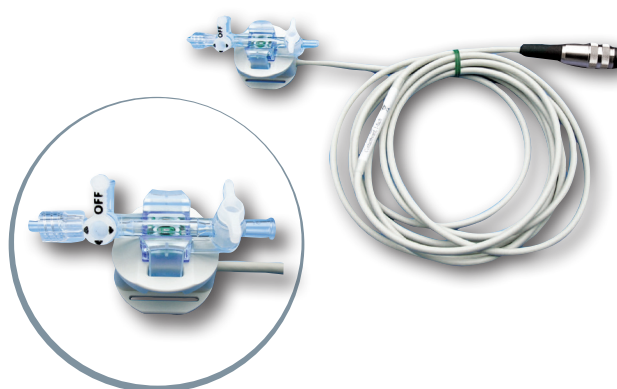

The APT300 transducer is an inexpensive pressure transducer which can be used to measure arterial blood pressures in all species, even on mice with a high heart rate.

It can be used for measurement of arterial pressure in vivo as well as for perfusion pressures in isolated perfused organs such as heart or kidney. It can also be used to measure isovolumetric left ventricular (using a balloon) pressures in isolated hearts from mice up to rabbits or pigs.

The transducer consists of a contact plate with cable and the exchangeable transducer head, which can easily be replaced. Contact plates with cables for different amplifier types are available.

APT300 Blood Pressure Transducer Specifications

OPERATING PRESSURE	-300 to 300 mmHg
OVERPRESSURE	4,000 mmHg
SENSITIVITY	5 μ V/V/mmHg ($\pm 1\%$)
TEMPERATURE COEFFICIENT	< 0.1% / $^{\circ}$ C
ZERO DRIFT	< 0.2 mmHg / $^{\circ}$ C
ZERO OFFSET	< 25 mmHg
EXCITATION VOLTAGE	2 – 15 V DC (or AC up to 5kHz)
ISOLATION AGAINST FLUID	> 5,000 V
OPERATING TEMPERATURE	15 $^{\circ}$ to 40 $^{\circ}$ C
STORAGE TEMPERATURE	-25 $^{\circ}$ to 70 $^{\circ}$ C
VOLUME DISPLACEMENT	< 0.04 mm 3 /100 mmHg
OUTPUT IMPEDANCE	356 Ohm $\pm 1\%$
FREQUENCY RESPONSE	> 1 KHz
CABLE LENGTH	3 m (9.8 ft)

Order #	Product
73-3862	APT300 Pressure Transducer for PLUGSYS TAM Amplifier
73-3869	Holder for APT300 Transducer, 8 mm Rod, Length 75 mm (3 in)
73-0500	Lab Stand with Triangular Base Plate with 30 cm (11.8 in) Rod
73-4140	Lab Stand with Triangular Base Plate with 16 cm (6.3 in) Rod
73-4479	Manual Pressure Calibration Kit, Range 0 to 300 mmHg

Pressure Transducers for PHD ULTRA™ CP Syringe Pump (continued)

P75 Venous Pressure Transducer & P1500 Pressure Transducer

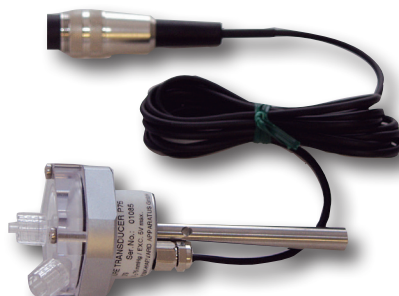

P75 Venous Pressure Transducer

The P75 has a removable Macrolon® dome with a pressure connection and a vent connection at the side, so that it can be filled free of air bubbles. The dome connections have a male Luer taper so that suitable stopcocks* can be attached. The transducer has a metal housing. The actual pressure sensor inside is made from ceramic and therefore has excellent resistance to different media. The transducer's rugged construction can withstand pressure overloads up to 4000 mmHg without damage. It works together with any DC bridge amplifier (e.g., PLUGSYS TAM-A).

P1500 Pressure Transducer

For applications requiring constant pressure control in the 0-30 PSI (0-2 bar) range, we offer the P1500 Pressure Transducer. Like the P75, it has a removable Macrolon® dome with a 90° pressure connection and 45° vent connection on the top side for filling the dome bubble free. The dome connections have a male Luer lock so that suitable stopcocks* can be attached. The transducer has a metal housing. The actual pressure sensor inside is made from ceramic and therefore has excellent resistance to different media. The transducer works with any DC bridge amplifier (e.g. PLUGSYS TAM-A) but is supplied with the connector for the TAM. Configurations for other amplifiers available upon request.

*Use one each of 73-0096 three-way stopcock and 73-0097 one-way stopcock

Order #	Product
73-0020	Blood Pressure Transducer P75 for PLUGSYS TAM Amplifier
73-3806	Blood Pressure Transducer P1500 for PLUGSYS TAM Amplifier

P75 and P1500 Pressure Transducers Specifications		
Model	P75 Pressure Transducer	P1500 Pressure Transducer
PRESSURE RANGE	±75 mmHg (±100 cmH ₂ O)	±1,500 mmHg (±30 PSI)
OVERLOAD	-760 (=vacuum) to 4,000 mmHg	13,500 mmHg
SENSITIVITY	1 mV/mmHg, nominal	0.05 mV/mmHg, nominal
TEMPERATURE RANGE	0° to 50°C	-20° to 80°C
ZERO DRIFT	±0.04 mmHg/10°C (0° to 50°C)	±0.5% FS (-20° to 80°C)
RANGE DRIFT	±0.04 mV/10°C (±0.04 mmHg/10°C) (0° to 50°C)	±0.5% FS (-20° to 80°C)
LONG-TERM DRIFT	±0.04 mmHg FS/Year	±0.1% FS/Year
VOLUME DISPLACEMENT	0.06 mm ³ /10 mmHg	0.004 mm ³ /10 mmHg
FREQUENCY RANGE	0 to 100 Hz	0 to 300 Hz
OUTPUT RESISTANCE	300 Ω, nominal	
EXCITATION VOLTAGE	5 V (4.5 to 5.5 V) DC only	
PRESSURE CONNECTIONS	Male Luer Lock	
CONNECTION CABLE	1.5 m (4.9 ft) long	
MOUNTING ROD, OD x L	8 x 70 mm (0.31 x 2.76 in)	

Pressure Transducers for PHD ULTRA™ CP Syringe Pump (continued)

Electronic Pressure Calibrator



KEY FEATURES

- Maintenance free precision pressure generation
- 4 units available:
 - 0 to 200 mmHg
 - 0 to 300 mmHg
 - 0 to 20 mmH₂O
 - 0 to 200 mmH₂O
- Calibration certificate on request

The calibrator KAL 84 is used for calibrating pressure sensors. A critical step in properly calibrating the CP pump across the appropriate output range of the amplifier involves the generation of a known stable pressure. The KAL 84 represents a combination of a pressure generator (hand pump) and a pressure meter with digital display. The instrument provides a simple means for testing and calibrating both pressure sensors and complete pressure measuring equipment.

After the unit has been switched on and connected to the pressure sensor to be calibrated (test object), the required pressure is set with the small hand-wheel. The built-in pressure meter measures the set pressure accurately and indicates it in digital form. Since the generated pressure is identical at the built-in pressure meter and at the test object, the pressure measured by the test object corresponds exactly to the pressure indicated by the KAL 84.

Models with different pressure ranges are available. Each model has an application-specific range (range 1) and can be switched to a corresponding SI range (range 2) in Pascal (Pa) or Kilopascal (kPa).

Electronic Pressure Calibrator Specifications

RANGE	Measurement and calibration range for appropriate model (see table below)
LINEARITY	±0.5% FS ±1 digit for mercury models, ±1% FS ±1 digit for water models
HYSTERESIS	0.1% FS
OVERPRESSURE LIMIT	200% FS for mercury models 500% FS for water models
RESPONSE TIME	TE = 20 ms, time constant can be switched to 0.1 sec or 1 sec
ANALOG OUTPUT	0 to 1 V for 100% nominal range, load resistance at least 2 kΩ
TEMPERATURE RANGE:	
NOMINAL	+10°C to +50°C
OPERATING	0°C to +60°C
PRESSURE CONNECTIONS	6.5 mm OD for 5 mm ID tubing
POWER SUPPLY	9 V rechargeable battery, mains adapter
DIMENSIONS, H X W X D	100 x 260 x 180 mm (3.9 x 10.2 x 7.1 in)
WEIGHT	Approx. 3 kg (6.6 lb)
OPTIONAL CERTIFICATE	Linearity test certificate, DKD (German calibration service, see below)

Order # Product

73-0977	Calibration Certificate with KAL84 Purchase
73-2918	Recalibration of KAL84 with Certificate (Requires Return of Unit)

Electronic Pressure Calibrators

115 VAC, 60 HZ	230 VAC, 50 HZ	MODEL	LIQUID	RANGE 1	RANGE 2	USED FOR CALIBRATION OF
73-0012	73-0013	KAL 84 H	Mercury	0 to 199.9 mmHg	0 to 26.66 kPa	Blood Pressure Transducers
73-0014	73-0015	KAL 84 SH	Mercury	0 to 300.0 mmHg	0 to 39.99 kPa	Blood Pressure Transducers
73-0016	73-0017	KAL 84 L	Water	0 to 19.99 mmH ₂ O	0 to 196.0 Pa	Low-Range Differential Pressure Transducers

Pressure Transducers for PHD ULTRA™ CP Syringe Pump (continued)

Disposable Pressure Transducer TRA023HS

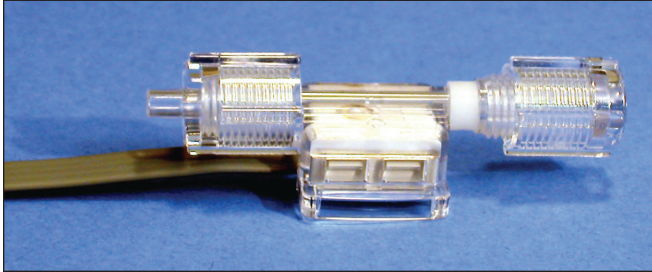

The Harvard Apparatus Research TRA023HS is a lower-cost semi-disposable pressure transducer with an in-line configuration which is suitable for use with most arterial and venous blood pressure measurements.

The TRA023HS is designed to work with the PLUGSYS TAM-A or TAM-D amplifiers and is supplied with an instruction manual and a calibration certificate.

Disposable Pressure Transducer Specifications

PRESSURE RANGE	-50 to 300mmHg
OVERLOAD	-500 to 5000 mmHg
SENSITIVITY	5 μ V/V/mmHg
OPERATING TEMPERATURE	15°C to 40°C
EIGHT HOUR DRIFT	1 mmHg after 10 min. warm-up.
EXCITATION VOLTAGE	2 to 5 VDC
STORAGE TEMPERATURE RANGE	30°C to 60°C
OPERATING LIFE	500 hours

Order #	Product
76-0498	TRA023 Disposable Research Pressure Transducer for PLUGSYS TAM Amplifier

Millar Pressure Catheters



2F Pressure Catheter SPR-407

Millar pressure catheters continue to represent the gold standard for high-fidelity pressure measurements for both systematic and intraventricular applications.

Adapters and cables are available to connect catheters directly to the range of Harvard Apparatus pressure amplifiers.

Order #	Model	Product
Adapters and Cables		
72-9842	HEC-10C	Pressure Catheter with Viking Connector to PLUGSYS TAM Amplifier
72-9843	HEC-10D	Pressure Catheter with Low Profile Connector to PLUGSYS TAM Amplifier
Millar Pressure Catheters		
72-9781	SPR-1000	1F, Single pressure, 20 cm, Straight, Non-repairable (Low Profile)
72-9779	SPR-671	1.4F Single pressure, 1.1F-2F body 15 cm from tip, 65 cm (Low Profile)
72-9775	SPR-407	2F Sensor, 1.5F Body, Single Pressure, 140 cm, Straight (Viking)
72-9777	SPR-524	3.5F Single pressure, 100 cm, Straight, Non-repairable (Viking)

Harvard Apparatus Stainless Steel Syringes



inch SWAGelok® tip only. The 8 ml stainless steel syringe contains two Perfluoroelastomer O-Ring seals and two PTFE O-Ring seals. This syringe is available with a 1/16 inch or 1/8 inch SWAGelok® tip.

High Pressure 20 ml to 200 ml Stainless Steel Syringes

Both syringe barrel end plungers are #316 stainless steel. A Viton O-Ring between top and end of the barrel insures against leakage. Syringes are guaranteed to be leak free for pressures up to 750 psi.

All syringes are supplied with inside diameter dimensions for use with Harvard Apparatus microprocessor controlled pumps and rate charts for use with older 'classic' pumps. Replacement Viton O-Rings are available, as are the more chemically resistant Perfluoroelastomer O-Rings.

For illustration and syringe dimensions, see next page.

KEY FEATURES

- 7500 psi peak pressure (with 2.5 ml syringes)
- Fits most Harvard Apparatus pumps
- Electron beam welded
- Fully autoclavable
- 1/16 inch SWAGelok® fitting for low dead volume

High Pressure Stainless Steel Syringes

Harvard Apparatus offers a complete line of Stainless Steel Syringes intended for high pressure applications with good resistance to most aggressive liquids. Wetted parts are #316 stainless steel or Viton. Syringes are available in 2.5, 8, 20, 50, 100 and 200 ml sizes with removable, replaceable tips. Genuine SWAGelok® syringe to tube fittings are available in 1/16, 1/8 and 1/4 inch sizes. A Luer lock end fitting is also available. All tips are interchangeable with all syringes (20 to 200 ml) in the series.

High Pressure 2.5 ml and 8 ml Stainless Steel Syringes

These syringes have been designed to utilize the high forces available in our syringe pumps to produce pressures up to 7,500 psi and 1,500 psi respectively. The 8 ml syringe is constructed entirely of #316 stainless steel. The barrel of the 2.5 ml syringe is #316 stainless steel and the plunger is #400C stainless steel. The 2.5 ml stainless steel syringe contains one Perfluoroelastomer O-Ring seal and one Ball seal. This syringe is available with a 1/16

Order #	Product
Replacement Parts	
Chemraz 505	
5013-087	Perfluoroelastomer Barrel O-Ring 8 ml
5013-089	Perfluoroelastomer Barrel O-Ring 20 ml
5013-090	Perfluoroelastomer Barrel O-Ring 50 ml
5013-091	Perfluoroelastomer Barrel O-Ring 100 ml
5013-092	Perfluoroelastomer Barrel O-Ring 200 ml
5013-110*	Perfluoroelastomer Tip Seal O-Ring 2.5 ml and 8 ml
5013-109	Perfluoroelastomer Tip Seal O-Ring 20 ml to 200 ml
Viton	
72-2472	Replacement Viton O-Ring 20 ml, pkg. of 10
72-2473	Replacement Viton O-Ring 50 ml, pkg. of 10
72-2474	Replacement Viton O-Ring 100 ml, pkg. of 10
72-2475	Replacement Viton O-Ring 200 ml, pkg. of 10
72-2616	Replacement Viton Tip Seal O-Ring, 20 ml to 200 ml, pkg. of 20
Other	
70-2271	Replacement Ball Seal for 2.5 ml
5013-088	Replacement Backup PTFE O-Ring, 8 ml

High Pressure Stainless Steel Syringes

SYRINGE SIZE	THREAD	With SWAGelok®			With Luer Lock
		DIAMETER 1/16 INCH	DIAMETER 1/8 INCH	DIAMETER 1/4 INCH	
2.5 ml	1/4 -28 inch	70-2269	N/A	N/A	N/A
8 ml	1/4 -28 inch	70-2267	70-2268	N/A	N/A
20 ml	3/8 -24 inch	70-2251	70-2252	70-2253	70-2254
50 ml	3/8 -24 inch	70-2255	70-2256	70-2257	70-2258
100 ml	3/8 -24 inch	70-2259	70-2260	70-2261	70-2262
200 ml	3/8 -24 inch	70-2263	70-2264	70-2265	70-2266
Replacement Tips, Furnished with Sealing O-Ring					
2.5 ml	N/A	70-2246	N/A	N/A	N/A
8 ml	N/A	70-2246	70-2245	N/A	N/A
20 to 200 ml	N/A	70-2247	70-2248	70-2249	70-2250

Harvard Apparatus Stainless Steel Syringes (continued)

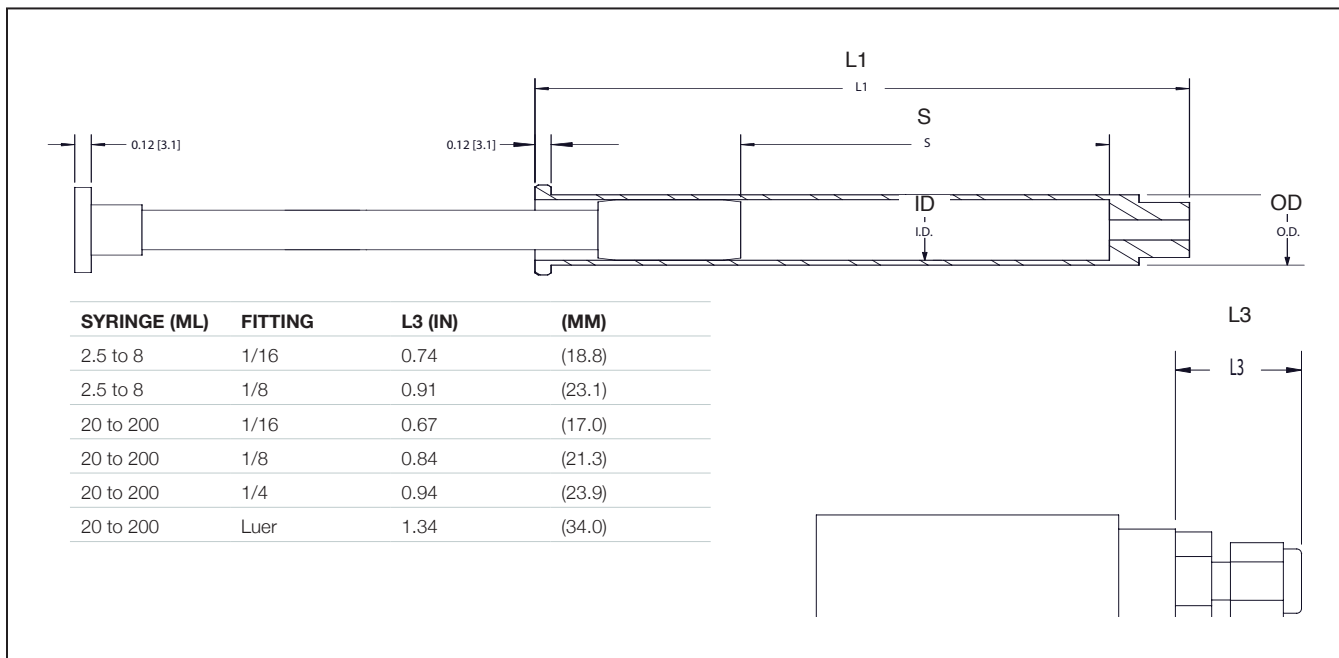

Harvard Apparatus Stainless Steel Syringes Specifications												
VOLUME	2.5 ml		8 ml		20 ml		50 ml		100 ml		200 ml	
MAXIMUM TEST PRESSURE	9,000 psi		4,000 psi		1,500 psi		1,500 psi		1,500 psi		1,500 psi	
WORKING PRESSURE	7,000 psi		1,500 psi		750 psi		750 psi		750 psi		750 psi	
DIMENSIONS	in	(mm)	in	(mm)	in	(mm)	in	(mm)	in	(mm)	in	(mm)
OVERALL LENGTH OF BARREL -(L1)	6.625	(168.3)	6.73	(170.8)	4.73	(120.1)	5.49	(139.3)	6.73	(170.9)	81.48	(215.4)
PLUNGER EXCURSION -(S)	4.75	(120.6)	4.42	(112.4)	3.56	(90.3)	4.14	(105.2)	5.67	(143.9)	7.20	(182.8)
OUTSIDE DIAMETER -(OD)	0.50	(12.7)	0.50	(12.7)	0.88	(22.2)	1.25	(31.8)	1.50	(38.1)	1.88	(47.63)
INSIDE DIAMETER -(ID)	0.191	(4.85)	0.375	(9.525)	0.753	(19.13)	1.126	(28.60)	1.374	(34.90)	1.762	(44.75)

Hamilton™ Glass Syringes

Harvard Apparatus offers a complete line of syringes in a variety of styles and sizes. We have introduced a broad selection of Hamilton™ microliter and specialty syringes along with an extensive selection of Kendall Monoject® plastic syringes. Our syringe selection continues to grow. Please visit our website or contact our technical support department for the latest offerings.

KEY FEATURES

- Sizes from 0.5 µl to 100 ml syringes available
- Nine different styles of Hamilton™ syringes from which to choose
- 5 different terminations
- Standard and instrument plunger styles available
- Standard and GASTIGHT® syringes
- Specialty syringes and accessories

Syringe Terminations

Syringes end in one of the following configurations:

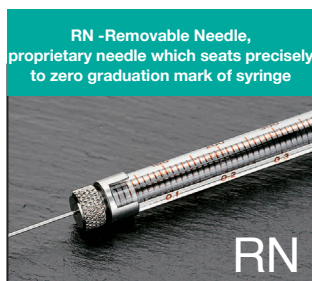

Point Styles
 RN and KH needles are available in two different point styles. Point style 2 is a non-coring Huber-like bevel. Point style 3 is blunt.

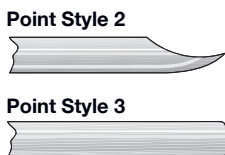

Hamilton syringes are considered the industry standard for precision fluid delivery. Harvard Apparatus offers a broad selection of these precision syringes which, when combined with our syringe pumps, offer fluid delivery with unparalleled accuracy and precision. A variety of syringe terminations are available to interface with virtually any system or experimental protocol. Hamilton microliter syringe options include: reinforced syringe plungers, reinforced syringe barrels, and GASTIGHT® syringes with syringe volumes from 0.5 µl to 100 ml (for standard glass syringes). Many syringes have replaceable plungers and barrels. Several accessories are also available for the microliter syringes including syringe guides for added plunger stability and cleaning wires and solution to maximize the life of your syringe.

All Hamilton™ glass syringes are autoclavable when disassembled except for syringes with cemented needles.

Syringe Plungers

Most are fine wire with button plungers. Some are interchangeable/replaceable

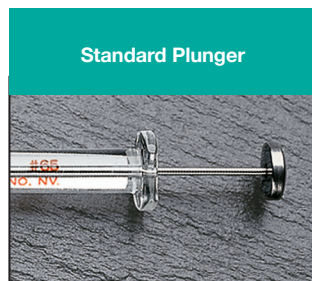

X Suffix (e.g. TLLX & CX)

Indicates syringe with Instrument stop, recommended for use with syringe pumps or drives for microliter syringes to prevent damage. Only available for 1700 series GASTIGHT® syringes.

Special Needle Sizes

An “s” following the needle gauge indicates a special size, see below.

Special Needle Sizes (mm)			
GAUGE THICKNESS	OD	ID	WALL
22s	0.72	0.15	0.28
25s	0.51	0.15	0.18

All other gauges listed are standard dimensions, see page 114 for needle size chart. Custom needle tips, gauges and lengths are available, call for more information.

Hamilton™ Glass Syringes

Some additional suggestions to assist you in selecting the best syringe for your application.

- **Reinforced Plunger** – Select this style if your setup or application may cause the plunger to bend (Series 800 and 1800 syringes, see pages 50 and 51).
- **Replaceable Barrel Syringes** – Select this style if your setup or application may cause the barrel to break or bend (Series 800, 1000 and 1700 syringes, see pages 50 and 51).
- **Removable Needles** – Select syringes with LT or TLL termini along with either disposable or reusable needles. For our complete selection of Luer needles including sterile disposable, non-sterile and specialty needles, please visit our website.
- **Chem Terminus** – Select syringes with a C terminus if you

Hamilton™ Neuros™ Syringes.

- **Accurately dispenses 50 nl to 100 µl of liquid to an exact location**
- **Maintains rigidity and creates the smallest injection site possible**
- **Little to no dead volume which eliminates sample loss and saves money**

See next page for full product details.

Syringe Graduations								
100 LINE SCREENS								
7000 Series Modified Microliter Syringes	0.5 µl	1 µl	2 µl	5 µl				
Scale Length, cm	6	6	6	6				
Total Scale Divisions	100	100	100	100				
Major Graduations, µl	0.05	0.1	0.2	0.5				
Minor Graduations, µl	0.01	0.02	0.04	0.1				
Sub-Minor Graduations, µl	0.005	0.01	0.02	0.05				
700 & 800 Series Microliter Syringes	5 µl	10 µl	25 µl	50 µl	100 µl	250 µl	500 µl	
	75, 85	701, 801	702, 802	705, 805	710, 810	725, 825	750	
Scale Length, cm	5.41	5.41	6	6	6	6	6	
Total Scale Divisions	100	100	100	100	100	100	100	
Major Graduations, µl	0.5	1	2.5	5	10	25	50	
Minor Graduations, µl	0.1	0.2	0.5	1	2	5	10	
Sub-Minor Graduations, µl	0.05	0.1	0.25	0.5	1	2.5	5	
1700 & 1800 Series Gastight Syringes	10 µl	25 µl	50 µl	100 µl	250 µl	500 µl		
	1701, 1801	1702, 1802	1705, 1805	1710, 1810	1725, 1825	1750		
Scale Length, cm	6	6	6	6	6	6		
Total Scale Divisions	100	100	100	100	100	100		
Major Graduations, µl	1	2.5	5	10	25	50		
Minor Graduations, µl	0.2	0.5	1	2	5	10		
Sub-Minor Graduations, µl	0.1	0.25	0.5	1	2.5	5		
1000 Series Gastight Syringes	1 ml	1.25 ml	2.5 ml	5 ml	10 ml	25 ml	50 ml	100 ml
	1001	1001.25	1002	1005	1010	1025	1050	1100
Scale Length, cm	6	6	6	6	6	6	6	12
Total Scale Divisions	100	100	100	100	100	100	100	200
Major Graduations, ml	0.1	0.125	0.25	0.5	1	2.5	5	5
Minor Graduations, ml	0.02	0.025	0.05	0.1	0.2	0.5	1	1
Sub-minor Graduations, ml	0.01	0.0125	0.025	0.05	0.1	0.25	0.5	0.5
Super Syringes	500 ml	1000 ml	1500 ml	2000 ml				
	S0500	S1000	S1500	S2000				
Scale Length, inches	6.53	6.57	9.85	13.13				
Total Scale Divisions	25	50	75	100				
Major graduations, ml	100	100	100	100				

Hamilton™ Glass Syringes (continued)

Neuros™ Syringes

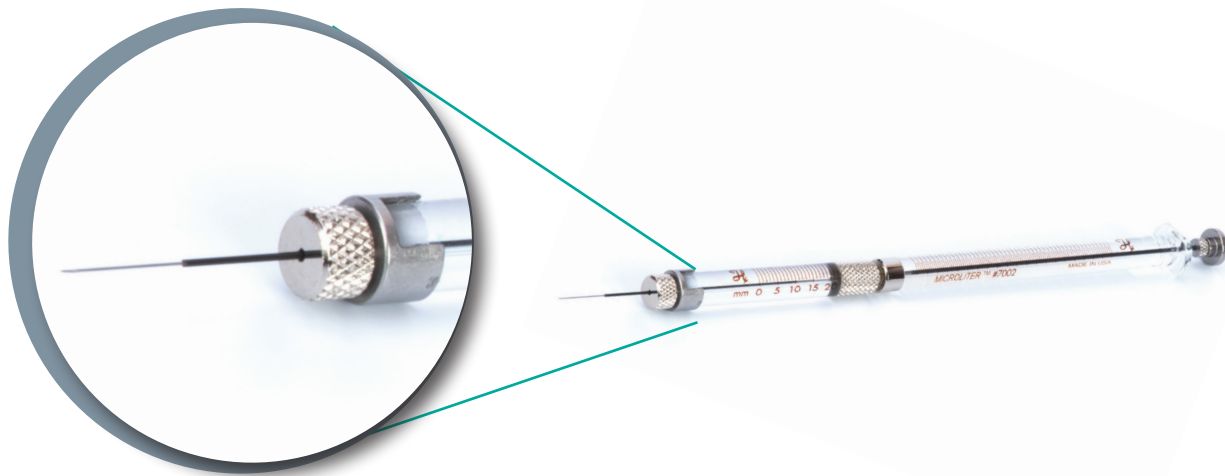

KEY FEATURES

- Accurately dispenses 50 nl to 100 µl of liquid to an exact location
- Maintains rigidity and creates the smallest injection site possible
- Little to no dead volume which eliminates sample loss and saves money
- Two sleeve options – one with a blind stop for cannulated animals and another without for stereotaxic holders
- Adjustable needle exposure of 0 to 20 mm gives you full control

Hamilton Neuros™ syringe technology provides unprecedented functionality for controlled animal injections. The Neuros accurately dispenses volumes between 50 nl to 100 µl through an ultrafine needle with a blunt point (point style 3).

Developed specifically for neuroscience applications, the Neuros syringe enables the delivery of microvolumes to an exact location while minimizing injection site damage. Neuros syringes come with two types of protective needle sleeves. The sleeve with a blind stop is perfect for cannulated applications and ensures targeted administration with an adjustable penetration depth. The version without a blind stop works best with stereotaxic holders. Both types provide an adjustable needle exposure of 0 to 20 mm.

These new Neuros™ Syringes are compatible with Harvard Apparatus syringe pumps.

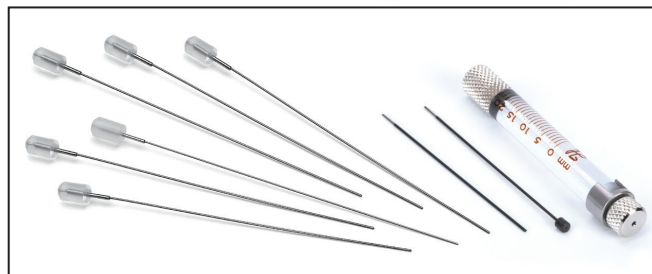

Order #	Product
75-0015	0.5 µl Neuros 7000 Series KH Syringe
75-0016	1.0 µl Neuros 7000 Series KH Syringe
75-0017	2.0 µl Neuros 7000 Series KH Syringe
75-0018	5.0 µl, Model 75 RN Neuros Syringe
75-0019	10 µl 1700 Series RN Syringe and Neuros Adapter Kit
75-0020	25 µl 1700 Series RN Syringe and Neuros Adapter Kit
75-0022	100 µl 1700 Series RN Syringe and Neuros Adapter Kit
75-0024	Neuros Replacement Needle, 33 gauge, Small Hub RN Needle, 3.03 in, point style 3, 6/pk

Hamilton™ Glass Syringes (continued)

800 Series Syringes



Syringe sizes from 5 to 250 µl available. Reinforced plunger: Replaceable plunger barrel assembly. Syringes supplied

800 Series Syringes						Replacement Parts	
ORDER #	Vol.	Ter.	Point Style	Ga.*	Needle (pkg. of 6)	Plunger Barrel Assembly	
72-1724	5 µl	RN	2	26s	72-5744	72-1730	
72-1725	10 µl	RN	2	26s	72-5744	72-1731	
72-1726	25 µl	RN	2	22s	72-5745	72-1732	
72-1727	50 µl	RN	2	22s	72-5745	72-1733	
72-1728	100 µl	RN	2	22s	72-5745	72-1734	
72-1729	250 µl	RN	2	22s	72-5746	72-1735	

7000 Series Modified Microliter™ Syringes



Ultra low volume syringes: 0.5 to 5 µl. No Dead Volume – sample contained entirely in needle. Replaceable syringe barrels and parts. The KH repair kit includes KH needle, KH ferrule, plunger wire and instruction sheet. Cannot substitute different size needles. Syringes supplied individually.

7000 Series Modified Microliter™ Syringes					
ORDER #	Volume	Terminus	Point Style	Gauge	KH Repair Kit
72-1736	0.5 µl	KH	2	25	72-1749
72-1737	1 µl	KH	2	25s	72-1750
72-1738	1 µl	KH	2	22s	72-1751
72-1739	2 µl	KH	2	25	72-1752
72-1740	2 µl	KH	2	23	72-1753
72-1741	5 µl	KH	2	24	72-1754
72-1742	0.5 µl	KH	3	32	72-1755
72-1743	0.5 µl	KH	3	25	72-1756
72-1744	1 µl	KH	3	25s	72-1757
72-1745	1 µl	KH	3	22s	72-1758
72-1746	2 µl	KH	3	25	72-1759
72-1747	2 µl	KH	3	23	72-1760
72-1748	5 µl	KH	3	24	72-1761

1700 Series GASTIGHT® Syringes



PTFE tipped plungers. Replaceable plungers and needles. Sizes: 10 to 500 µl. Syringes supplied individually. Replacement needles are sold in packages of 6.

1700 Series GASTIGHT® Syringes							Replacement Parts		
ORDER #	Vol.	Ter.	Ga.*	Needle (pkg. of 6)	Plunger	Barrel			
72-1762	10 µl	LT	-	-	-	72-1785	-		
72-1763	25 µl	LT	-	-	-	72-1786	-		
72-1764	50 µl	LT	-	-	-	-	-		
72-1765	100 µl	LT	-	-	-	-	-		
72-1766	250 µl	LT	-	-	-	72-1789	-		
72-1767	500 µl	LT	-	-	-	-	-		
72-1824	5 µl	RN	3	32	72-5743	-	-		
72-1825	10 µl	RN	3	32	72-5743	72-1785	-		
72-1768	10 µl	RN	2	26s	72-5744	72-1785	-		
72-1769	25 µl	RN	2	22s	72-5745	72-1786	-		
72-1770	50 µl	RN	2	22s	72-5745	72-1792	-		
72-1771	100 µl	RN	2	22s	72-5745	72-1793	-		
72-1772	250 µl	RN	2	22s	72-5746	72-1794	-		
72-1773	500 µl	RN	2	22	72-7139	72-1795	-		
72-1774	10 µl	RN	3	22s	72-5751	72-1785	-		
72-1775	25 µl	RN	3	22s	72-5751	72-1786	-		
72-1776	50 µl	RN	3	22s	72-5751	72-1792	-		
72-1777	100 µl	RN	3	22s	72-5751	72-1793	-		
72-1778	250 µl	RN	3	22s	72-5753	72-1794	-		
72-1779	500 µl	RN	3	22	72-5752	72-1795	-		
72-1781	50 µl	TLL	-	-	-	72-1792	-		
72-1782	100 µl	TLL	-	-	-	72-1793	72-1798		
72-1783	250 µl	TLL	-	-	-	72-1794	72-1799		
72-1784	500 µl	TLL	-	-	-	72-1795	72-1800		
72-1780	25 µl	TLLX	-	-	-	72-1791	-		
72-1901	50 µl	TLLX	-	-	-	72-1808	-		
72-1902	100 µl	TLLX	-	-	-	72-1809	72-1798		
72-1903	250 µl	TLLX	-	-	-	72-1810	72-1799		
72-1904	500 µl	TLLX	-	-	-	72-1811	72-1800		
72-1801	10 µl	CX	1/4-28	-	-	-	-		
72-1802	25 µl	CX	1/4-28	-	-	72-1791	-		
72-1803	50 µl	CX	1/4-28	-	-	72-1808	72-1907		
72-1804	100 µl	CX	1/4-28	-	-	72-1809	72-1908		
72-1805	250 µl	CX	1/4-28	-	-	72-1810	72-1909		
72-1806	500 µl	CX	1/4-28	-	-	72-1811	72-1910		

* Note: An "s" after the gauge size refers to a special needle size

Hamilton™ Glass Syringes (continued)

700 Series Syringes



Economical Microliter Syringes. Barrels and plungers are NOT interchangeable or replaceable. Syringe sizes from 5 to 500 µl available. Syringes supplied individually.

700 Series Syringes**						
72-1717	5 µl	RN	2	26s	72-5744	
72-1822	5 µl	RN	3	32	72-5743	
72-1718	10 µl	RN	2	26s	72-5744	
72-1823	10 µl	RN	3	32	72-5743	
72-1719	25 µl	RN	2	22s	72-5745	
72-1720	50 µl	RN	2	22s	72-5745	
72-1721	100 µl	RN	2	22s	72-5745	
72-1722	250 µl	RN	2	22s	72-5746	
72-1723	500 µl	RN	2	22	72-7139	
72-1711	10 µl	LT	-	-	-	
72-1712	25 µl	LT	-	-	-	
72-1713	50 µl	LT	-	-	-	
72-1714	100 µl	LT	-	-	-	
72-1715	250 µl	LT	-	-	-	
72-1716	500 µl	LT	-	-	-	

* Note: An "s" after the gauge size refers to a special needle size, see chart on page 50.

1800 Series GASTIGHT® Syringes

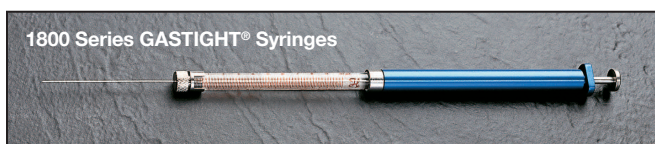

Reinforced, PTFE tipped plungers. Replaceable plunger assembly and needle. Syringe sizes from 10 to 250 µl available. Syringes supplied individually.

1800 Series GASTIGHT® Syringes						
ORDER #	Volume	Terminus	Point Style		Replacement Needle (pkg. of 6)	
72-1812	10 µl	RN	2	26s	72-5744	
72-1813	25 µl	RN	2	22s	72-5745	
72-1814	50 µl	RN	2	22s	72-5745	
72-1815	100 µl	RN	2	22s	72-5745	
72-1816	250 µl	RN	2	22s	72-5746	

* Note: An "s" after the gauge size refers to a special needle size, see chart on page 50.

1000 Series GASTIGHT® Syringes



PTFE tipped plungers. Replaceable plungers and needles sizes: 1 to 100 ml, Terminus: LT, TLL, RN, C. Syringes supplied individually.

1000 Series GASTIGHT® Syringes							Replacement Parts	
ORDER #	Volume	Ter.	Point Style	Gauge	Needle (pkg. of 6)	Plunger Assembly		
72-1826	1 ml	LT	-	-	-		72-1894	
72-1828	2.5 ml	LT	-	-	-		72-1896	
72-1829	5 ml	LT	-	-	-		72-1897	
72-1830	10 ml	LT	-	-	-		72-1898	
72-1831	1 ml	TLL	-	-	-		72-1894	
72-1832	2.5 ml	TLL	-	-	-		72-1896	
72-1833	5 ml	TLL	-	-	-		72-1897	
72-1834	10 ml	TLL	-	-	-		72-1898	
72-1835	25 ml	TLL	-	-	-		72-1899	
72-1836	50 ml	TLL	-	-	-		72-1900	
72-1837	100 ml	TLL	-	-	-		-	
72-1838	1 ml	RN	2	22	72-7139	72-1894		
72-1839	2.5 ml	RN	2	22	72-7139	72-1896		
72-1840	5 ml	RN	2	22	72-7139	72-1897		
72-1841	10 ml	RN	2	22	72-7139	72-1898		
72-1842	1 ml	C	-	1/4-28	-	72-1894		
72-1843	2.5 ml	C	-	1/4-28	-	72-1896		
72-1844	5 ml	C	-	1/4-28	-	72-1897		
72-1845	10 ml	C	-	1/4-28	-	72-1898		

* Note: If using with a Harvard Apparatus syringe pump and withdrawal is required, please order plunger adaptor 55-8000 for Hamilton syringe sizes 25 ml and greater.

Constant Rate Syringes



Spring-driven plunger injects samples at a constant rate. Incremental volumes are selectable with mm precision. Volumes: 20, 50, 200 µl. Syringes supplied individually.

Order #	Product			Point Style
72-1854	Constant Rate Syringe, 20 µl	22s	2 in	3
72-1855	Constant Rate Syringe, 50 µl	22	2 in	3
72-1856	Constant Rate Syringe, 200 µl	22	2 in	3

* Note: An "s" after the gauge size refers to a special needle size, see chart on page 50.

Specialty Syringes and Accessories

Threaded Plunger Syringes

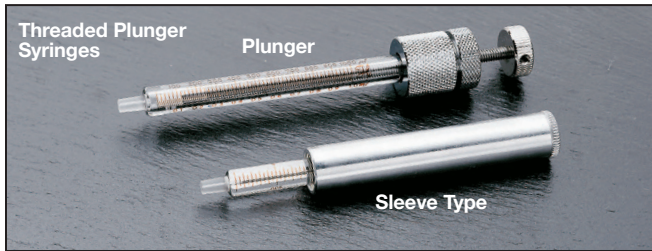

For applications requiring extremely precise plunger movement or minute fluid manipulation, LT (Luer Tip) Terminus Volumes from 25 µl to 1 ml. Syringes supplied individually.

Threaded Plunger Syringes			
ORDER #	Volume	Description	Dispense Volume
72-1857	25 µl	Sleeve Type	0.33 µl/revolution
72-1859	100 µl	Sleeve Type	1.32 µl/revolution
72-1862	500 µl	Plunger Type	5.29 µl/revolution
72-1863	1 ml	Plunger Type	13.23 µl/revolution

Cadence Science Glass Syringes

These are standard glass Syringes with Luer Lock tips. The barrels and plungers of the same-sized Syringes are interchangeable. Syringes supplied individually.

Cadence Science (formerly Popper & Sons) Micro-Mate Glass Syringes			
ORDER #	Syringe Size	Order #	Syringe Size
75-1010	5 cc	75-1012	30 cc
75-1011	10 cc	75-1013	50 cc
		75-1014	100 cc

Glass Syringe with Robb Tip, 100 ml

The plunger and barrel of this glass Syringe are ground and mated for a tight fit. They are not interchangeable with other barrels or plungers. The parts are numbered for easy reassembly.

This Syringe dispenses large volumes in short time periods. Therefore, it has a Robb tip (Luer Lock) with a 12 gauge bore of 0.223 cm (0.088 in). 100 ml size only. Syringes supplied individually.

Order #	Product
55-1002	Becton-Dickinson Yale Glass Syringe with Robb Tip, 100 ml



Syringe Guides

Prevent syringe plunger from bending. For manual (hand held) operation only. Adjustable Stop. Works with 700, 1700 and 7000 series syringes.

ORDER #	Volume	For Use with Syringe Series		
		700	1700	7000
72-1868	0.5 to 5 µl			•
72-1867	5 to 10 µl	•		
72-1867	5 to 10 µl		•	
72-1868	25 to 500 µl	•		
72-1868	25 to 500 µl		•	



Needle Cleaning Kit

Fine gauge tungsten wires used to clear plugged needles. Biodegradable cleaning solutions are used to remove residues from syringe needles and barrels. All cleaning wires are 7 inches long and are sold in packages of 10. Cleaning concentrate is sold separately.

Order #	Product	
	Cleaning Wires	
	To Clean Needle Gauge	
	Wire Size OD	
72-1873	23s, 26s, 31 to 33	0.0762 mm (0.00300 in)
72-1874	26s, 31 to 33	0.0889 mm (0.00350 in)
72-1875	22s, 25s, 28 to 30	0.1262 mm (0.00497 in)
72-1876	27	0.1674 mm (0.00659 in)
72-1877	24 to 26	0.2070 mm (0.00815 in)
72-1878	22, 23	0.3066 mm (0.01207 in)
72-1879	Cleaning Concentrate, 70 ml	
72-1880	Cleaning Concentrate, 500 ml	
72-1872	All Cleaning Wires and 70 ml of Cleaning Concentrate	



Removable (RN) Adapters

Provides connection of Luer fittings to RN syringes > 250 µl.

Order #	Product
72-1869	RN Hub to Female Luer
72-1870	RN Hub to Male Luer
72-1871	RN Hub to Male Luer Lock

Plastic Syringes

Single Use Monoject® Plastic Syringes



APPLICATIONS

- Syringe volumes from 0.3 to 1 cc
- Rigid or blister packaging
- Permanent or detachable needle
- ACCU-TIP syringe plunger

These syringes feature a new resin which provides greater clarity while still possessing all the same functional characteristics and biocompatibility requirements as traditional polypropylene syringes. They are packaged either Sterile or Non-Sterile. Rigid pack syringes feature a tamper-evident heat stake. There are five different syringe tip styles from which to choose.

Single Use Monoject Plastic Syringes

							Box of 100	
Volume	Needle Gauge	Needle Length	Needle* Attachment	Pack Type	Safety Shield	Order #	Qty	
0.3 cc	29	0.5 in	P	Blister	–	72-2419	300	
0.3 cc	29	0.5 in	P	Rigid	Yes	72-2420	500	
0.5 cc	28	0.5 in	P	Rigid	–	72-2421	500	
0.5 cc	28	0.5 in	P	Blister	–	72-2422	300	
0.5 cc	29	0.5 in	P	Blister	–	72-2424	300	
0.5 cc	29	0.5 in	P	Rigid	Yes	–	500	
1 cc	25	0.625 in	D	Rigid	–	–	500	
1 cc	25	0.625 in	P	Rigid	–	72-2427	500	
1 cc	25	0.625 in	P	Rigid	Yes	–	500	
1 cc	26	0.375 in	D	Rigid	–	72-2429	500	
1 cc	27	0.5 in	D	Rigid	–	72-2430	500	
1 cc	28	0.5 in	P	Rigid	–	72-2432	500	
1 cc	28	0.5 in	P	Blister	–	72-2433	300	
1 cc	28	0.5 in	P	Rigid	Yes	–	500	
1 cc	29	0.5 in	P	Blister	–	72-2435	300	
1 cc	29	0.5 in	P	Rigid	Yes	72-2436	500	

*Note: P -Permanent; D -Detachable

Becton Dickinson Plastic Syringes

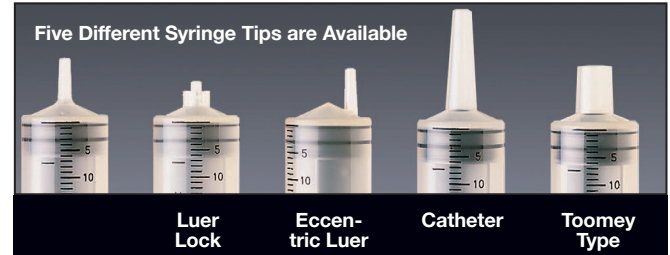

These individually packaged plastic sterile syringes come standard with a Luer Lock connector. They are available in six sizes. See the table below for size and quantity information.

Becton Dickinson Plastic Syringes

ORDER #	Syringe Size	Graduation	Qty./Box
59-8377	3 ml	1/10 ml	100
59-8378	5 ml	1/5 ml	125
59-8379	10 ml (3/4 oz)	1/5 m (1/8 oz)	100
59-8380	20 ml (1 oz)	1 ml (1/8 oz)	40
59-8381	30 ml (2 oz)	1 ml (1/4 oz)	40
59-8382	60 ml	1 ml	40

Choosing the Right Pump for Your Application & Budget

KEY FEATURES

- Broad selection of pumps for every application
- Wide range of flow rates ml/hr to L/min
- Single and multi-channel models available with up to 24 channels
- Continuous delivery and batch mode dispensing

PERISTALTIC PUMP QUESTIONS

- How many channels (tubes) will be used simultaneously?
- What size tubing will be used (inner diameter)?
- What flow rate(s) will be used?
- What is the total volume to be delivered?
- Do you need continuous flow?
- Does the pump need to be battery operated?
- Do you need to control the pump with a computer?
- Do you need to weigh your dispenses?
- Do you need analog control?
- Does the pump need to have TTL capabilities (external control of valves, use of footswitch etc)?

Peristaltic Pump Selection Guide							
PUMP MODEL	Model P-70	Model P-230	Model P-1500	Model P-1500 with weight scale integration	MPII	Model 720	Model 720
ORDER #	70-7000	70-7001	70-7002	70-7008	70-2027	72-0001	61-0098
NUMBER OF CHANNELS	5	4	1	1	1 to 2	1 to 2	1 to 2
NUMBER OF ROLLERS	8	8	4	4	4	3	3
TUBE SIZE (INNER DIAMETER)	0.13 to 2.79 mm (0.005 to 0.11 in)	0.13 to 3.17 mm (0.005 to 0.13 in)	0.8 to 4.8 mm (0.03 to 0.19 in)	0.8 to 8 mm (0.03 to 0.314 in)	1.6 mm (1/16 in)	0.38 to 2.4 mm (0.015 to 0.093 in)	0.38 to 2.4 mm (0.015 to 0.093 in)
FLOW RATE (ML/MIN/PER CHANNEL):							
Minimum	0.001	0.001	0.01	0.001	0.8	0.07	0.008
Maximum	70	230	1,500	1,500	12.25/24.50	18	2.4
COMPUTER CONTROL	Yes (USB)	Yes (USB)	Yes (USB)	Yes (USB)	No	No	No
TTL CONTROL	Yes	Yes	Yes	Yes	No	No	No
ANALOG CONTROL	Yes	Yes	Yes	Yes	No	Yes	Yes
POWER	100 to 240 VAC, 50/60 Hz	100 to 240 VAC, 50/60 Hz	100 to 240 VAC, 50/60 Hz	100 to 240 VAC, 50/60 Hz	115 to 230 VAC, 50/60 Hz	120 VAC, 50 Hz, 230 VAC, 60 Hz	120 VAC, 50 Hz, 230 VAC, 60 Hz
BATTERY BACKUP	No	No	No	No	No	No	No
DIMENSIONS (H x W x D)	11.5 x 25.4 x 11.8 cm (4.5 x 10 x 4.63 in)	16 x 23.6 x 11.8 cm (6.3 x 9.3 x 4.6 in)	11.5 x 24.1 x 11.8 cm (4.5 x 9.5 x 4.6 in)	11.5 x 24.1 x 11.8 cm (4.5 x 9.5 x 4.6 in)	18.9 x 11.4 x 10.5 cm (3.5 x 4.5 x 4 in)	6.4 x 5.7 x 10.2 cm (2.5 x 2.25 x 4 in)	6.4 x 5.7 x 10.2 cm (2.5 x 2.25 x 4 in)
WEIGHT	2.27 kg (10.55 lb)	2.5 kg (5.5 lb)	2.5 kg (5.5 lb)	2.5 kg (5.5 lb)	0.96 kg (2.1 lb)	375 g (13.2 oz)	375 g (13.2 oz)
CATALOG PAGE	48	48	48	49	50	51	51

* Depends upon Pump Drive.

Choosing the Right Pump for Your Application & Budget (continued)

Harvard Apparatus offers an extensive selection of peristaltic pumps to suit the needs of a wide range of research applications. Pumps which offer features such as multi-channel pumping, computer control, analog control, low electrical noise and a wide range of fluid flow rates are now available. The following table was designed to answer most questions regarding our continuous flow pumps. Please contact our technical support department for further assistance.

Peristaltic and Continuous Flow Pumps

Traditional peristaltic pumps utilize a series of rollers to push fluid through tubing held within a pump head. Peristaltic flow is typically pulsatile, but can be made smoother with the use of more rollers in the pumping head. Our Mini-Peristaltic Pump (MPLI, see page 61) features two speed ranges, reversibility and dual channel pumping at a very reasonable price. Many pumps offer external control either through the input of an analog signal proportional to the speed or by RS-232 (serial) communication.

Peristaltic Pump Selection Guide							
PUMP MODEL	Model 720	Model 720	REGLO Masterflex	REGLO ICC	Gentle Pump Heads	Pump Head 380AD	SB Pump Head
ORDER #	72-4048	72-4049	SEE PAGE 65 & 66	SEE PAGE 67	SEE PAGE 74	73-3026	SEE PAGE 76
NUMBER OF CHANNELS	1 to 2	1 to 2	2 or 4	2, 3 or 4	1	1	1 to 3
NUMBER OF ROLLERS	3	3	6, 8 or 12	6, 8 or 12	2 or 3	3	6
TUBE SIZE (INNER DIAMETER)	0.38 to 2.4 mm (0.015 to 0.093 in)	0.38 to 2.4 mm (0.015 to 0.093 in)	0.13 to 3.17 mm (0.01 to 0.12 in)	0.13 to 3.17 mm (0.01 to 0.12 in)	1.6 to 11.1 mm (0.06 to 0.44 in)	0.8 to 11.1 mm (0.03 to 0.44 in) or 4.8 to 6.4 mm (0.19 to 0.25 in)	0.8 to 6.4 mm (0.03 to 0.25 in) or 3.2 to 8.0 mm (0.13 to 0.31 in)
FLOW RATE (ML/MIN/PER CHANNEL):							
Minimum	0.0008	0.0002	0.001	0.0002	0.45	0.41	0.09 or 1.1
Maximum	0.20	0.058	38/57/68	43	3,700	1,500	870 or 1,100
COMPUTER CONTROL	No	No	Yes (Digital)	Yes (USB/RS-232)	n/a*	n/a*	n/a*
TTL CONTROL	No	No	No	No	n/a*	n/a*	n/a*
ANALOG CONTROL	Yes	Yes	Yes (Analog)	No	n/a*	n/a*	n/a*
POWER	120 VAC, 50 Hz, 230 VAC, 60 Hz	120 VAC, 50 Hz, 230 VAC, 60 Hz	90 to 260 VAC	115 to 230 VAC, 50/60 Hz	n/a*	n/a*	n/a*
BATTERY BACKUP	9 V Lithium Battery up to 30 hours	9 V Lithium Battery up to 30 hours	No	No	n/a*	n/a*	n/a*
DIMENSIONS (H x W x D)	6.4 x 5.7 x 10.2 cm (2.5 x 2.25 x 4 in)	6.4 x 5.7 x 10.2 cm (2.5 x 2.25 x 4 in)	8.7" x 5.8" x 6.3" (22.1 x 14.7 x 15.7 cm)	14 x 17 x 29 cm (5 x 7 x 11 in)	n/a*	n/a*	n/a*
WEIGHT	375 g (13.2 oz)	375 g (13.2 oz)	2.1 kg (4.6 lb)	5.3 kg (11.7 lb)	n/a*	n/a*	n/a*
CATALOG PAGE	51	51	52	53	56	57	58

* Depends upon Pump Drive.

Harvard Peristaltic Pumps



Pump with P-1500 Motor Drive 70-7005

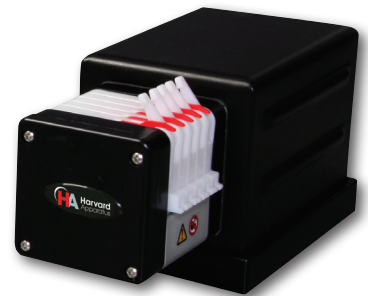

Pump with P-70 Motor Drive 70-7003

Pump with P-230 Motor Drive 70-7004



Harvard Peristaltic Pump Control Box 70-7006

KEY FEATURES

- Remote Design
- Interchangeable Pumps
- Programmable

The Harvard Peristaltic Pump series offers unparalleled accuracy, reproducibility, and ease of use over a broad range of flow rates. Other benefits include:

- The ability to separate the motor drive from the controller to facilitate use and save space in incubators and fume hoods
- A library of tubing sizes is stored in the pump's memory minimizing set up time
- Custom tubing can be used allowing complete flexibility
- A full range of interchangeable motor drives to allow for economical ease of use over a broad flow rate range.

The Harvard Peristaltic Pump consists of a control unit and a series of motor drives. The pump can deliver solutions over a range of flow rates from 0.001 to 1,500 ml/min depending on the motor drive used. Three interchangeable motor drive modules provide flow over the following ranges:

- P - 70 drive provides flow rates from 0.001 to 70 ml/min
- P - 230 drive provides flow rates from 0.001 to 230 ml/min
- P - 1500 drive provides flow rates from 0.001 to 1,500 ml/min

A complete range of programmable functions allow the pump to be easily adapted to a wide range of dispensing applications. The

pump has pre-programmed flow profiles for:

- Constant Flow
- Flow Ramps
- Pulsatile Flow
- Concentration Based Fluid Delivery

In addition to the flow profiles, the pump has advanced user

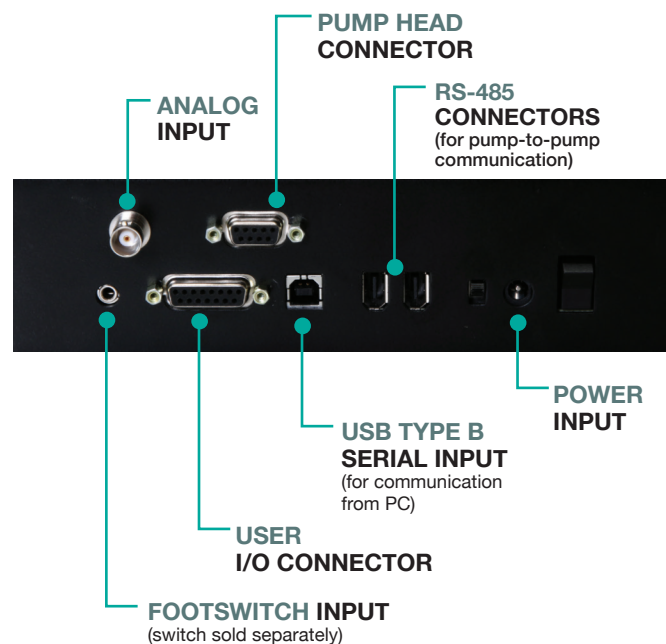

Harvard Peristaltic Pumps (continued)



Harvard Peristaltic Pump Quick Start Screen

All settings can easily be saved as user generated methods in the pump's memory. The method can be easily recalled and run very quickly, saving researchers valuable time.

Connectivity to a wide range of external input or output devices is easily accomplished.

The pump will automatically rotate at the proper RPM for the tube selection and flow rate chosen. To further increase the accuracy, Harvard Peristaltic Pumps offer a rapid calibration routine to further optimize flow accuracy by entering a measured volume of fluid collected.

OTHER CAPABILITIES INCLUDE:

- **Single Channel or combined channel mode for setting flow rate**
- **Timed Dispense: Dispenses for a fixed time at a set flow rate**
- **Volume Dispense: Dispenses a fixed volume on start**
- **Foot Switch Control Option**
- **Analog Control Option**
- **Bidirectional Delivery**

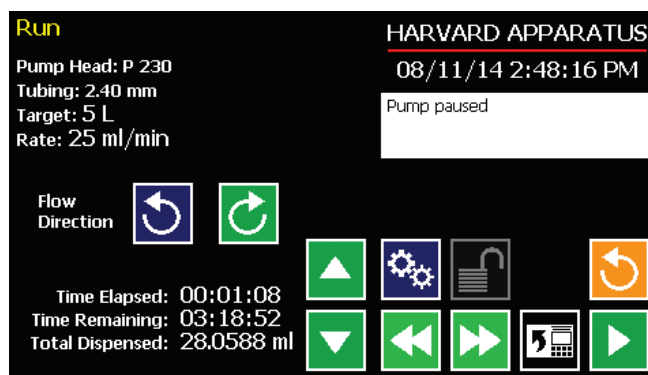

Harvard Peristaltic Pump Run Screen

Harvard Peristaltic Pump Specifications, Control Box and Pump with Motor Drive

DESCRIPTION	PUMP WITH P-70 MOTOR DRIVE	PUMP WITH P-230 MOTOR DRIVE	PUMP WITH P-1500 MOTOR DRIVE
Type	8 rollers, 5 channels	8 rollers, 4 channels	4 rollers, 1 channel
Accuracy	±1.0%	±1.0%	±1.0%
TTL Connector	15-pin D-sub	15-pin D-sub	15-pin D-sub
Computer Interface	USB Type 'B'	USB Type 'B'	USB Type 'B'
Pump-to-Pump	IEEE 1394	IEEE 1394	IEEE 1394
Back pressure	15 psi	15 psi	30 psi
Tubing ID	0.13 to 2.79 mm (0.005 to 0.11 in)	0.13 to 3.17 mm (0.005 to 0.13 in)	0.8 to 8 mm (0.03 to 0.314 in)
Flow Rate Range*	0.001 to 70 ml/min	0.001 to 230 ml/min	0.001 to 1,500 ml/min
Dimensions: Control Box	20.7 x 13 x 9.6 cm (8.13 x 5.13 x 3.75 in)	20.7 x 13 x 9.6 cm (8.13 x 5.13 x 3.75 in)	20.7 x 13 x 9.6 cm (8.13 x 5.13 x 3.75 in)
Dimensions: Pump Head	11.5 x 25.4 x 11.8 cm (4.5 x 10 x 4.63 in)	16 x 23.6 x 11.8 cm (6.3 x 9.3 x 4.63 in)	11.5 x 24.1 x 11.8 cm (4.5 x 9.5 x 4.63 in)
Weight	4.7 kg (10.5 lb)	5 kg (11 lb)	5 kg (11 lb)
Pump Voltage	30 VDC, 1.67 A	30 VDC, 1.67 A	30 VDC, 1.67 A
Power Supply	100 to 240 VAC, 50/60 Hz	100 to 240 VAC, 50/60 Hz	100 to 240 VAC, 50/60 Hz
For Compatible Tubing	See page 81	See page 81	See page 81
ORDER #	70-7000	70-7001	70-7002

Replacement Parts

ORDER #	PRODUCT
70-7003	P-70 Motor Drive, 8 rollers, 5 channel
70-7004	P-230 Motor Drive, 8 rollers, 4 channel
70-7005	P-1500 Motor Drive, 4 rollers, 1 channel
70-7006	Control Box for all P Series Motor Drives
70-7009	Control Box with Weight Scale Integration
72-0604	Replacement Cartridge/Cassette for P-70
73-3052	Replacement Cartridge/Cassette for P-230

Harvard Peristaltic Pump P-1500 with Weight Scale Integration



KEY FEATURES

- Intuitive touchscreen with integrated weight scale control
- Automatically dispenses to predefined sample weight
- User selectable auto-tare, slow-down and anti-drip features
- Key pump and scale parameters clearly displayed
- Remote pump head can be palced up to 5 ft (1.5 M) from controller

APPLICATIONS

- Reproductive biotechnology sampling
- Organic solvent dispensing
- Automated weighing of food samples

The Harvard Apparatus P-1500 Peristaltic Pump with Weight Scale integration allows the user to dispense fluids based on units of weight. The peristaltic controller provides scale communication allowing the pump to query the scale during operation for precise dispensing. The Weight Scale option is compatible with the Ohaus Defender, Ranger, Explorer, Adventurer and Scout (with RS-232 option) series along with the Mettler Toledo (with RS-232 option).

Specifications

PUMP MODEL	P-1500 with Weight Scale Integration
NUMBER OF CHANNELS	1
NUMBER OF ROLLERS	4
TUBE SIZE (INNER DIAMETER)	0.8 to 8mm (0.03 to 0.314 in)
FLOW RATE (ML/MIN/CHANNEL)	Tubing Size Dependent
MIN/MAX	0.001 ; 1.500
COMPUTER CONTROL	Yes
ITL CONTROL	Yes
ANALOG CONTROL	Yes
POWER	100 to 240 VAC, 50/60 Hz
WEIGHT	2.5 kg (5.5 lb)

**Note: P70 and P230 Motor Drives are also compatible with weight scale control. The feature will only work with one or combined channels. Please consult the factory for additional information.*

Order Information

Order #	Product
70-7008	P-1500 with Weight Scale Integration
Replacement Parts	
70-7005	P-1500 Motor Drive, 4 rollers, 1 channel
70 7009	Control box with Weight Scale Integration
2601046	Scale to Controller Cable (DB9 to RJ-11)

MP II Mini-Peristaltic Pump



KEY FEATURES

- Continuous low flow rates ideal for:
 - Slow perfusion studies
 - Controlled animal feeding
- Pump can take one or two tubes simultaneously, 1/16 inch ID
- Toggle switches for direction and x1 or x2 speed range selection
- Low electrical and mechanical noise
- Small size

The Harvard MP II Mini-Peristaltic Pump takes only one size of tubing, 1.6 mm ID x 3.2 mm OD (1/16 x 1/8 in). It can be used with either a single tube or two tubes simultaneously. Two of the 55-4148 Pump Head Tubing Pieces are included with the pump. Additional Pump Head Tubing Pieces (55-4148) may be purchased separately.

Two front panel controls provide flow rates from approximately 0.8 to 24.5 ml/min. The control knob provides variable adjustment from 0 to 100% of the selected flow rate range. The second control is a two position toggle switch marked x1, x2 which selects low or high flow rates, see table to right.

The easy-loading four-roller pump head is on top of the stout metal box. The back of the pump head effortlessly rotates into an 'open' position and either one or two tubes can be dropped into slots. The loaded section simply rotates back against spring loaded jaws and locks into place. The tubing is automatically in proper wiping contact with the pump head rollers. Each Pump is provided with a 12.5 mm (0.5 in) rod clamp on the back so that multiple pumps can be mounted vertically on a lattice rod.

MP II in ml/min Flow Rates

Switch Setting	WITH ONE TUBE		WITH TWO TUBES	
	Minimum	Maximum	Minimum	Maximum
x1	0.8 ml/min	7.00 ml/min	1.6 ml/min	14.00 ml/min

MP II Specifications

OUTPUT PRESSURE	In excess of 20 p.s.i.
POWER	12 VDC 800 mA, 2.5 mm Connector, 115-230 VAC, 50/60 Hz, Universal power supply, 10 W
DIMENSIONS, H x W x D	189 x 114 x 105 mm (3.5 x 4.5 x 4 in)
WEIGHT	0.96 kg (2.1 lb)

Order # Product

70-2027	MP II, 115/230 VAC, 50/60 Hz
55-4148	Pump Head Tubing Pieces. These Silicone Pump Head Tubing Pieces Have Connectors on Each End for 1/16 in ID Tubing 2.5 in, pkg. of 10

Harvard/Instech Model 720

Compact Peristaltic Pumps and Tubing

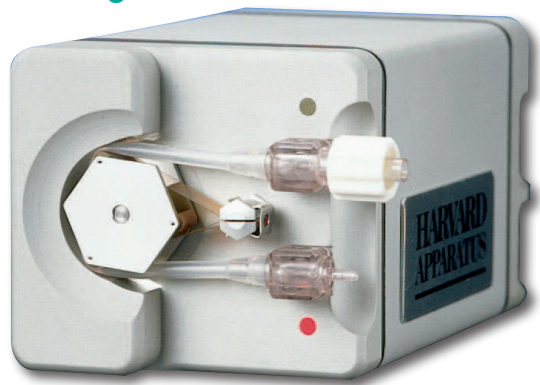

KEY FEATURES

- Continuous infusion
- Battery back-up (30 hrs)
- Compact pump
- Minimal electromagnetic radiation

The Instech Model 720 Compact Peristaltic Pumps are a stand-alone pump series with flow rates of 0.2 $\mu\text{l}/\text{min}$ to 18 ml/min (0.04 to 1100 ml/hr) depending upon the pump and tubing selected. These pumps deliver the accurate low flow rates of syringe pumps without the limits on delivered volume. They are ideal for animal IV infusion, tissue perfusion, and other low-flow laboratory applications.

Instech offers this pump with four different motors; choose the motor and tube set that best match your flow rate requirements. In general, use the standard 61-0098 for flows between 0.05 and 1 ml/min, the lower flow 72-4048 for rates between 5 and 100 $\mu\text{l}/\text{min}$, the ultra low flow 72-4049 for rates as low as 0.2 $\mu\text{l}/\text{min}$, and then the higher-flow 72-0001 for rates up to 18 ml/min (1 l/hr). With a given tube set, the pump performs best over a 10:1 flow control range.

The pump's analog circuitry has been carefully designed to minimize electromagnetic radiation; for this reason, the pump is often used for tissue perfusion even in the presence of sensitive intracellular recordings. It is also an ideal pump for applications which require limited size or weight, the versatility of single and dual tubes sets and/or external analog control.

An internal 9V lithium battery (supplied with 61-0098, 72-4048 and 72-4049) will run the pump for up to 30 hours, protecting your experiment in the event of a power failure. Due to its power requirements, the high flow version (72-0001) is not available with battery backup.

The pump is typically powered by a 1.25 V internal reference voltage. An external reference voltage can be used to regulate flow rate and direction (pump direction can only be reversed by analog control). Under external control the speed dials serve as voltage attenuators to limit the external voltage to ± 1.25 volts.

Tube sets must be purchased separately. Please see our website or contact technical support if you need assistance choosing the right tube set. For use with saline and most drugs, use silicone tubing. For use with solutions containing fats, such as IV diets, use C-FLEX® tubing.

Model 720 Specifications

ACCURACY	$\pm 5\%$
REPEATABILITY	$\pm 3\%$
FLOW CONTROL RANGE	20:1
POWER SOURCE	Universal 15 VDC 1A adapter, 2.5 mm male plug & tip
DIMENSIONS, H x W x D	6.4 x 5.7 x 10.2 cm (2.5 x 2.3 x 4 in)
WEIGHT	375 g (1 lb)
VOLTAGE RANGE	Universal input 100 to 240 VAC, 50/60 Hz

**Tube sets are not supplied with the pump. They must be purchased separately.

Tube Sets



A wide variety of tube sizes, tube materials and connector types allows you to tailor your peristaltic pump to your particular application.

Tube sets typically last about one month under continuous

operation. Dual channel tube sets place more stress on the pump than do single channel tube sets, which may shorten

Silicone Tubing Sets

Order #	Product
PC5 61-0241	1-Ch, 0.015" ID tubing, FLL to 22ga Luer 0.016" ID x 0.028" OD stub, pkg. of 5
PC5 61-0242	1-Ch, 0.020" ID tubing, FLL to 20ga Luer 0.024" ID x 0.036" OD stub, pkg. of 5
PC5 61-0243	1-Ch, 0.031" ID tubing, 0.062" ID Barbs, pkg. of 5
PC5 61-0244	1-Ch, 0.093" ID tubing, 0.062" ID Barbs, pkg. of 5
PC5 61-0245	2-Ch, 0.062" ID tubing, 0.062" ID Barbs, pkg. of 5

Flow Rate Ranges

	ORDER #	ORDER #	ORDER #	ORDER #
Tube ID	72-4049 Ultra Low Flow	72-4048 Very Low Flow	61-0098 Low Flow	72-0001 High Flow
0.015"	0.2 -2.2 $\mu\text{l}/\text{min}$	0.8 - 7.5 $\mu\text{l}/\text{min}$	8 -83 $\mu\text{l}/\text{min}$	70 -700 $\mu\text{l}/\text{min}$
0.020"	0.4 -4.6 $\mu\text{l}/\text{min}$	1.6 -16 $\mu\text{l}/\text{min}$	18 -180 $\mu\text{l}/\text{min}$	0.15 -1.5 ml/min
0.031"	0.9 -8.7 $\mu\text{l}/\text{min}$	3 -30 $\mu\text{l}/\text{min}$	35 -350 $\mu\text{l}/\text{min}$	0.3 - 2.8 ml/min
0.062"	3 -30 $\mu\text{l}/\text{min}$	10 -100 $\mu\text{l}/\text{min}$	125 -1,250 $\mu\text{l}/\text{min}$	0.9 - 9 ml/min
0.093"	6 -58 $\mu\text{l}/\text{min}$	20 -200 $\mu\text{l}/\text{min}$	240 -2,400 $\mu\text{l}/\text{min}$	1.8 -18 ml/min

Reglo Masterflex® Digital Peristaltic Pumps



- Reglo Masterflex® Digital Peristaltic Pumps are versatile multichannel pumps for accurate low-flow fluid delivery – with an intuitive touch-screen interface.
- Compact, benchtop pumps optimize ease of use, accuracy, and reliability 5" (12.7 cm) capacitive TFT/RGB touch screen for crisp resolution and a wide viewing angle
- Flexible operational control via screen, or analog remote control
- Continuous run, volume dispense, and time dispense modes batch control and interval/off time in Volume and Time modes
- Anti-drip and speed ramping available in Volume dispense mode – ensure accuracy and minimize sample loss
- Cassette pump models accept 3-stop tubing for easy loading and secure retention

Order #	Product
75-1000	Reglo Masterflex Digital 2-Channel 6-Roller Peristaltic Pump
75-1001	Reglo Masterflex Digital 2-Channel 8-Roller Peristaltic Pump
75-1002	Reglo Masterflex Digital 2-Channel 12-Roller Peristaltic Pump
75-1003	Reglo Masterflex Digital 4-Channel 6-Roller Peristaltic Pump
75-1004	Reglo Masterflex Digital 4-Channel 8-Roller Peristaltic Pump
75-1005	Reglo Masterflex Digital 4-Channel 12-Roller Peristaltic Pump
73-3054	MS/CA Cassette, Click 'N' Go

Specifications

	75-1000	75-1001	75-1002	75-1003	75-1004	75-1005
ENCLOSURE	IP31: Plastic housing with aluminum chassis and bezel					
MOTOR SPEED RANGE (RPM)	0.15 to 160	0.15 to 160	0.15 to 160	0.15 to 160	0.15 to 160	0.15 to 160
NUMBER OF CHANNELS	2	2	2	4	4	4
NUMBER OF ROLLERS	6	8	12	6	8	12
MIN FLOW RATE (ML/MIN/CHANNEL)	0.0002	0.0002	0.0001	0.0002	0.0002	0.0001
MAX FLOW RATE (ML/MIN/CHANNEL)	68	57	38	68	57	38
REMOTE ANALOG CONNECTION	25-pin D-Sub	25-pin D-Sub	25-pin D-Sub	25-pin D-Sub	25-pin D-Sub	25-pin D-Sub
THREE STOP TUBING SIZE RANGE	0.13 mm to 3.17 mm ID	0.13 mm to 3.17 mm ID	0.13 mm to 3.17 mm ID	0.13 mm to 3.17 mm ID	0.13 mm to 3.17 mm ID	0.13 mm to 3.17 mm ID
DIGITAL DISPLAY	5" capacitive TFT/RGB touch screen with in-plane switching (wide viewing angle); 800 x 480 pixels					
CONTROL FUNCTIONS	Start, speed, direction, internal/external control, anti-drip, volume/time/copy dispense, dispense sounds, auto restart, language, calibration, tubing size, prime, lock					
ACCURACY	0.1% / 0.1 RPM	0.1% / 0.1 RPM	0.1% / 0.1 RPM	0.1% / 0.1 RPM	0.1% / 0.1 RPM	0.1% / 0.1 RPM
POWER (VAC)	90 to 260 VAC	90 to 260 VAC	90 to 260 VAC	90 to 260 VAC	90 to 260 VAC	90 to 260 VAC
DIMENSIONS (L X W X H) WITH PUMP HEAD	.7" x 5.8" x 6.3" (22.1 x 14.7 x 15.7 cm)					

REGLO Independent Channel Control (ICC) Peristaltic Pumps



75-0511

- Continuous pumping or precision dispensing
- Flexibility of bi-directional flow in each channel
- Flow rate 0.002ml/min to 43 ml/min (model/tube size dependent)
- Easy-to-use tubing cassettes allow quick changeovers
- USB interface for quick connections
- Uses 3-stop tubing (see page 80)

The REGLO Independent Channel Control (ICC) Digital Multi-Channel Peristaltic Pumps allow individual control of the flow and direction of each fluidic channel. Each channel is independently programmable from the pump's intuitive keypad or via the computer.

REGLO Specifications							
REGLO Analog 2 Channel							
	75-0513	75-	75-0512	75-	75-0070	75-0515	75-0511
CHANNELS	2	2	2	3	3	3	4
PUMP ROLLERS	6	8	12	6	8	12	12
FLOW RATES	See Chart Below						
SPEED RANGE	0.1-100 rpm (0.01 rpm resolution)						
MAINS CONNECTION	100 to 240 VAC, 50/60 Hz						
POWER CONSUMPTION	30 W						
REVERSIBLE FLOW	30 W						
ACCURACY	±1						
USB 2.0 AND RS-232 INTER-	Remote control of all functions						
BACK PRESSURE, MAX.	1.0 bar (14.5 PSI)						
PROTECTION RATING	IP 30						
TUBING CASSETTE	MS/CA Click 'n' Go -Cassettes are included						
DIMENSIONS, H x W x D	170 x 125 x 205 mm (6.7 x 5.0 x 8.1 in)						
WEIGHT	2.7 kg (6 lbs)						

Order #	Product
75-0070	REGLO ICC Digital 3 Channels, 8 Rollers
75-0510	REGLO ICC Digital 2 Channels, 8 Rollers
75-0512	REGLO ICC Digital 2 Channels, 12 Rollers
75-0513	REGLO ICC Digital 2 Channels, 6 Rollers
75-0514	REGLO ICC Digital 3 Channels, 6 Rollers
75-0515	REGLO ICC Digital 3 Channels, 12 Rollers
75-0511	REGLO ICC Digital 4 Channels, 12 Rollers

REGLO ICC Peristaltic Pumps using 3-Stop Collard Tubing Flow Rates (mL/min per channel)			
	75-0513 AND 75-0514	75-0070 AND 75-0510	75-0511, 75-0512 AND 75-0515
TUBING ID (MM)	6 ROLLERS	8 ROLLERS	12 ROLLERS
0.13	0.0002 to 0.14	0.0002 to 0.11	0.0001 to 0.093
0.51	0.0019 to 1.9	0.0017 to 1.7	0.0016 to 1.6
0.57	0.0024 to 2.4	0.0021 to 2.1	0.0019 to 1.9
0.64	0.0030 to 3.0	0.0026 to 2.6	0.0024 to 2.4
0.95	0.0064 to 6.4	0.0056 to 5.6	0.0050 to 5.0
1.02	0.0073 to 7.3	0.0063 to 6.3	0.0056 to 5.6
1.42	0.013 to 13	0.011 to 11	0.0094 to 9.4
1.75	0.019 to 19	0.016 to 16	0.013 to 13
1.85	0.021 to 21	0.017 to 17	0.014 to 14
2.54	0.033 to 33	0.027 to 27	0.019 to 19
2.79	0.036 to 36	0.031 to 31	0.021 to 21
3.17	0.043 to 43	0.035 to 35	0.024 to 24

MCP Pump Drive

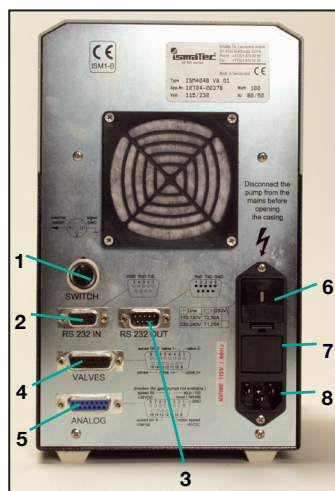

Rear panel of MCP

1. Foot Switch/Hand Dispenser
2. RS-232 Interface (in)
3. RS-232 Interface (out)
4. Valve Connector
5. Analog Interface
6. Voltage Selector
7. Fuse Holder
8. Mains Supply Socket

All functions of the MCP drive can be controlled via PC via the RS-232 interface

KEY FEATURES

- Stores 4 programs in memory
- Dispensing volumes in ml and flow rates in ml/min
- Calibrate in ml/min
- Various dispensing modes (time, volume, interval and flow rate, drip-free)
- MAX-key for priming and rapid filling or emptying of the tube system

APPLICATIONS

- Filling of bottles and test tubes
- Dispensing of pre-defined volumes

This programmable pump drive offers various dispensing modes, providing highly reproducible and accurate results. Pump head must be purchased separately. A wide selection of pump heads with single or multi-channel capabilities are available for the MCP pump drive. See pages 74 to 77.

Multi-functional Display

For tube sizes, speed, flow-rates, dispensing time, dispensing volume, interval duration and totally delivered volume as well as operational mode, flow direction and MAX-key for priming.

Calibration: Dispensing Volume/Flow Rate

Volume and flow rate can be pre-set and calibrated in ml or ml/min. The drives are pre-calibrated according to the pre-programmed pump heads and tube sizes.

Specifications

MODEL	MCP pump drive only, pump head must be purchased separately
SPEED	1 to 240 rpm with 0.1 rpm resolution
BACK PRESSURE	1.5 bar maximum (22 PSI)
MAINS CONNECTION	115 VAC (50/60 Hz) or 230 VAC (50/60 Hz)
POWER CONSUMPTION	100 W maximum
RS-232 INTERFACE 8 PUMPS	Baud rate 9600 or 1200 baud, 8 bit, 1 stop bit, no parity for complete computer control for cascade control or up to 8 pumps
ANALOG INTERFACE	Speed control 0–5 V or 0–10 V respectively 0–20 mA or 4–20 mA
DIGITAL INPUT (TTL LEVEL)	Flow direction, start/stop, speed control
VALVE PLUG	1 for 24 V valve
PROTECTION RATING	IP 30
ELECTRO MAGNETIC IMMUNITY	EN 50082-1
ELECTRO MAGNETIC RADIATION	EN 55022 Class B
OPERATING CONDITIONS	0° to 40°C (normal environmental conditions)
DIMENSIONS, H x W x D	260 x 155 x 220 mm (10.2 x 6.1 x 8.7 in) without pump head

Order # Product

73-3029	MCP Pump Drive, 115 VAC, 50/60 Hz
---------	-----------------------------------

BVP Pump Drive

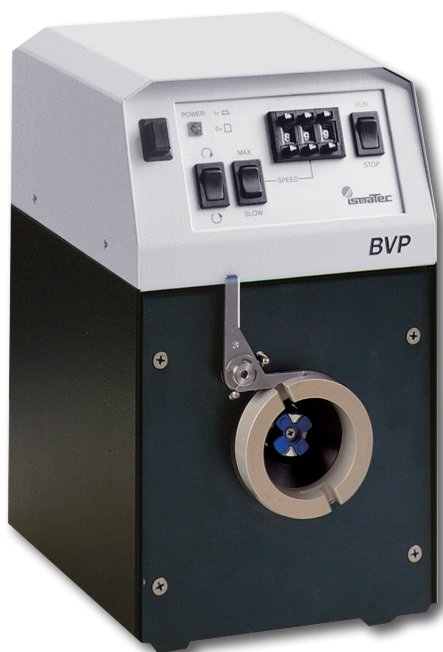

KEY FEATURES

- Smooth operation at a low noise level
- Robust drive for long-term operations
- Small footprint, 2 drives are stackable
- 3 digit potentiometer speed selector, adjustable in 0.1% steps, 1 to 99%
- MAX-Switch (e.g. for priming of the tubing system)
- Switchable flow direction for clockwise and counter-clockwise operation
- Suitable pump for SCP controller, part of the universal servo control perfusion system

The BVP pump drive is very robust and designed for continuous operation. It is equipped with a 3 digit potentiometer speed selector and an analog interface.

Pump Head must be purchased separately. A wide selection of pump heads with single or multi-channel capabilities are available for the BVP pump drive. See pages 74 to 78. Pump heads can be rapidly interchanged so that a single pump drive with multi-heads can fulfill a diverse range of pumping applications. The following table lists the single and multi-channel pump head options for the MCP/BVP drives with page references to the available tubing.

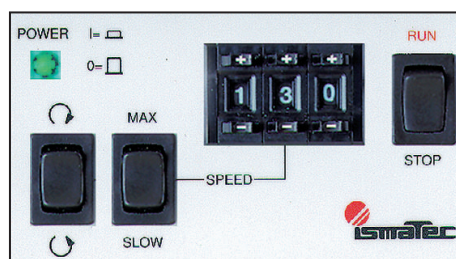

BVP Pump Drive Specifications

MODEL	BVP pump drive only, pump head must be purchased separately
SPEED	2.4 to 240 rpm, adjustable in 0.1 % steps
BACK PRESSURE	1.5 bar maximum (22 PSI)
MAINS CONNECTION	115 VAC (50/60 Hz) or 230 VAC (50/60 Hz)
POWER CONSUMPTION	100 W maximum
ANALOG INTERFACE	Speed control 0–5 V or 0–10 V respectively 0–20 mA or 4–20 mA
DIGITAL INPUT (TTL LEVEL)	Flow direction, start/stop
PROTECTION RATING	IP 30
ELECTRO MAGNETIC IMMUNITY	EN 50082-1
ELECTRO MAGNETIC RADIATION	EN 55022, Class B
OPERATING CONDITIONS	0° to 40 °C (normal environmental conditions)
DIMENSIONS, H x W x D	260 x 155 x 220 mm (9.8 x 6.1 x 8.7 in) without pump-head

Order #	Product
73-3028*	BVP Pump Drive, 230 VAC, 50/60 Hz
73-3027*	BVP Pump Drive, 115 VAC, 50/60 Hz
Single Channel Pump Head, see pages 74 and 75	
73-3035	380AD
73-3120	PRO-380
Multi-Channel Pump Head, see pages 76 to 78	
73-3036	CA-8
73-3040	SB (Requires Tube Bed Set)
73-3033	MS/CA8-6

* Pump head must be purchased separately.

Gentle Pumping Pump Heads

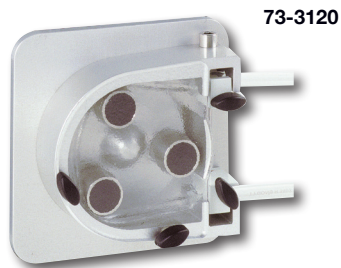

73-3120

KEY FEATURES

- Unique convex rollers cause minimal cell lysis
- Installs rapidly
- Easily interchanged with other MCP/BVP pump heads
- Ideal for mammalian cell inoculating, harvesting or cell suspension transfers
- Suitable for viscous fluids and fluids containing a high content of sensitive solids
- Applications requiring hygienic conditions, durability and reliability

PRO-380

- Coated aluminum pump head
- Can be dismantled for cleaning
- Stainless steel rollers
- Self-centering tube track, allows tube to lie in the optimum position, which considerably lengthens the tube life
- For applications which require hygienic conditions, reliability and durability
- Ideal for use in chemical, biotechnological and pharmaceutical processes and in food industry

These pump heads provide gentle pumping action and are suitable for many applications, including cell suspensions.

The model PRO-280 pump head is gentle enough to use for highly viscous liquids with concentrated viable cells. Comparisons to gear, piston and centrifugal pumps proved that peristaltic pumps are the only suitable and sterilizable pump system for gently pumping media containing living cells.

Gentle Pumping Pump Heads Specifications

PUMP HEAD	PRO-380
NUMBER OF CHANNELS	1
NUMBER OF ROLLERS	3
TUBING WALL THICKNESS	1.6 mm
FLOW RATE RANGE ML/MIN	0.45 -3,400

Gentle Pumping Pump Heads Flow Rates

Standard Tygon® R-3603/R-3607			
		PRO-380 FLOW RATE, ML/MIN FLOW RATE, ML/MIN	
Tubing ID mm	Wall mm	Min.	Max.
1.6	1.6	0.45	110
3.2	1.6	1.7	400
4.8	1.6	3.7	890
6.4	1.6	6.5	1,600
9.5	1.6	13	3,000
11.1	1.6	14	3,400

**Note: Approximate values: determined with water at 22°C, no differential pressure, with Tygon® Tubing*

Order # Product

73-3120	PRO-380 Gentle Pumping Head
---------	-----------------------------

Pump Head 380AD

Single-Channel
Pump Head

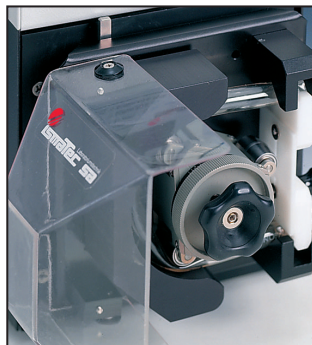
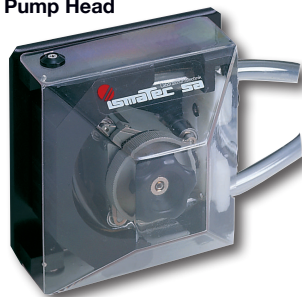

KEY FEATURES

- Installs rapidly
- Easily interchanged with other MCP/BVP pump heads
- Ideal for chemical, biotechnological and pharmaceutical applications
- Suitable for viscous fluids and fluids containing a high content of sensitive solids
- Applications requiring hygienic conditions, durability and reliability

This pump head features 3 convex rollers revolving in a concave tube bed which allows cells or particles to escape through a gap towards tubing wall to minimize damage. It is ideal for inoculating or harvesting mammalian cells.

Adjustable Pump Rollers

On this pump head, the 3 convex rollers can be adjusted and pressed symmetrically against the concave tube bed, enabling the use of pump tubing with various wall thicknesses.

Adjustable roller pressure accommodates wide range of tubing durometers (stiffness).

Very simple tube loading. This pump head accepts tubing with different diameters and wall thicknesses with ease. Thanks to the adjustable pump rollers, this is an ideal pump head for media with high viscosity, or with a certain level of solid content.

380AD Pump Head Specifications

PUMP HEAD	380AD
CHANNELS	1
PUMP ROLLERS	3
FLOW RATES	0.41 to 3600 ml/min
BACK PRESSURE	1.5 bar (22 PSI) maximum with 1.6 mm wall thickness tubing 2.5 bar (36 PSI) maximum with 2.4 mm wall thickness tubing
TUBING TYPE	Standard Tubing
TUBING ID	0.8 to 11.1 mm; 4.8 to 6.4 mm

380AD Pump Head Using Standard Tubing Flow Rates

Tubing ID	Wall Thickness	FLOW RATES, ML/MIN	
		Minimum	Maximum
1.6 mm	1.6 mm	0.41	99
3.2 mm	1.6 mm	1.5	370
4.8 mm	1.6 mm	3.4	830
6.4 mm	1.6 mm	6.2	1,500
8.0 mm	1.6 mm	9.5	2,300
9.5 mm	1.6 mm	13	3,000
11.1 mm	1.6 mm	15	3,600
4.8 mm	2.4 mm	3.4	830
6.4 mm	2.4 mm	6.2	1,500

**Note: Approximate values: determined with water at 22°C, no differential pressure, with Tygon® Tubing*

Order # Product

73-3035	380AD Single-Channel Pump Head for MCP/BVP Pump Drives
----------------	--

SB Pump Head with Tube Bed Sets, 2V or 3V

SB Pump Head with 2V Tube Bed

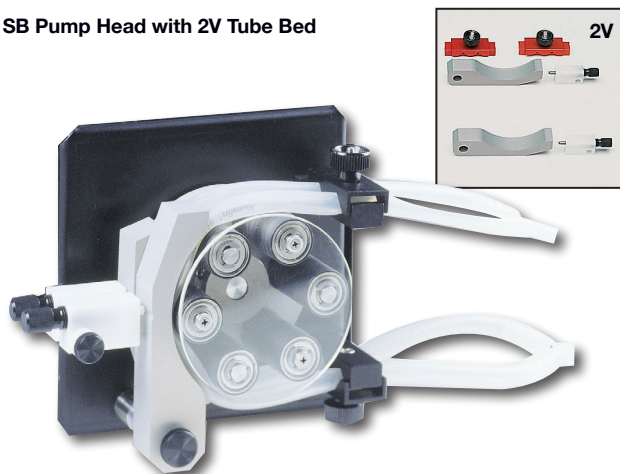

SB Pump Head with 3V Tube

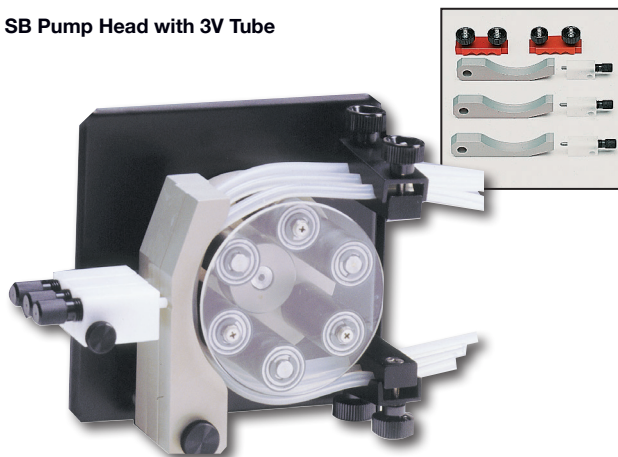

KEY FEATURES

- Ideal for sensitive substances requiring a smooth pressure adjustment
- Uses spring-loaded tube bed set – choice of 1, 2 or 3 channels
- Tube bed sets are interchangeable
- 0.009 to 1100 ml/min flow rates depending on tube bed set
- 6 rollers
- Individual and continuously adjustable pressure setting per channel

SB Pump Head Specifications

SB Pump Head with 2V Tube Bed Set

PUMP HEAD	SB
TUBE BED SET	2V
CHANNELS	1 – 2
PUMP ROLLERS	6
FLOW RATES	1.1 to 1100 ml/min
BACK PRESSURE	1.5 bar (22 PSI) maximum
TUBING TYPE	Standard tubing
TUBE ID	3.2 to 8.0 mm
TUBING WALL THICKNESS	1.6 mm

SB Pump Head with 3V Tube Bed Set

PUMP HEAD	SB
TUBE BED SET	3V
CHANNELS	1 – 3
PUMP ROLLERS	6
FLOW RATES	0.09 to 870 ml/min
BACK PRESSURE	1.5 bar (22 PSI) maximum
TUBING TYPE	Standard tubing

SB Pump Head using Standard Tubing, 1.6 mm Wall Thickness Flow Rates

Standard Tubing ID mm	2V TUBE BED SET, ML/MIN		3V TUBE BED SET, ML/MIN	
	min	max	min	max
0.8	—	—	0.09	22
1.6	—	—	0.26	63
3.2	1.1	260	0.99	240
4.8	2.3	550	2.2	530
6.4	3.7	890	3.6	870
8.0	4.6	1100	—	—

Note: For BVP-Standard drive, the min. flow rate values must be multiplied by factor 2.4

*Note: Approximate values: determined with water at 22°C, no differential pressure, with Tygon® Tubing

Order # Product

73-3040	SB Pump Head for BVP/MCP Pump Drives*
73-3045	2V Tube Bed Set for SB Pump Head
73-3046	3V Tube Bed Set for SB Pump Head

*Note: Requires selection of Tube Bed Set.

CA Pump Heads

73-3031
CA-4 Pump Head



73-3036
CA-8 Pump Head

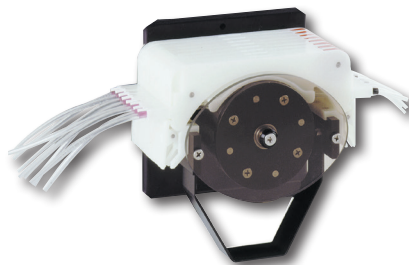

73-3037
CA-12 Pump Head

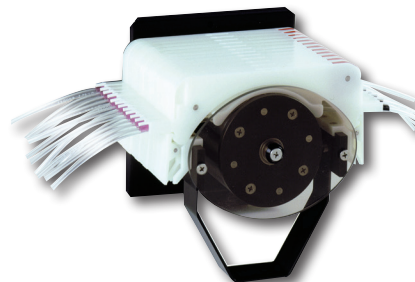

KEY FEATURES

- For use with MCP and BVP Pump Drive, see pages 72 and 73
- CA Click 'n' Go Cassettes are included
- Automatic pressure setting
- Easy and rapid tube change-over; each channel separately, even while pump is running
- 8 rollers
- 4, 8, or 12 channels, each channel can take different tube sizes
- Uses 2-stop collared tubing 0.13 to 3.17 mm ID, see page 81

The CA pump heads for the MCP/BVP pump drives, see pages 72 and 73, offer the widest flow rate range of any multi-channel pump head series available.

Other multi-channel pump heads include the MS/CA 4-12 and 8-6, see page 74. The MS/CA 4-12 and 8-6 multi-channel pump head series offer 8 rollers, and stackable head assemblies that allow you to increase the number of tubing channels per pump drive.

CA Pump Drive Specifications

PUMP ROLLERS	8
FLOW RATES	0.002 to 230 ml/min
BACK PRESSURE	1.0 bar maximum
TUBING TYPE	2-Stop Collared Tubing
TUBING ID	0.13 to 3.17 mm

CA Pump Heads Flow Rate Range

2-Stop Collared Tubing

ENE#	Tubing ID mm	ML/MIN PER CHANNEL	
		Minimum	Maximum
00	0.13	0.002	0.31
01	0.19	0.004	0.94
02	0.25	0.008	1.8
03	0.38	0.019	4.5
04	0.44	0.025	6.1
05	0.51	0.034	8.2
06	0.57	0.042	10
07	0.64	0.053	13
08	0.76	0.074	18
09	0.89	0.1	24
10	0.95	0.11	27
11	1.02	0.13	31
12	1.09	0.14	35
13	1.14	0.16	38
14	1.22	0.18	42
15	1.3	0.2	47
16	1.42	0.23	55
17	1.52	0.26	62
18	1.65	0.3	71
19	1.75	0.33	78
20	1.85	0.36	86
21	2.06	0.43	100
22	2.29	0.51	120
23	2.54	0.62	150
24	2.79	0.74	180
25	3.17	0.94	230

Note: For BVP-Standard drive, the minimum flow rate values must be multiplied by factor 2.4.

Order # Product

73-3035	CA-4 Pump Head 4 Channel for BVP/MCP Pump Drives
73-3036	CA-8 Pump Head 8 Channel for BVP/MCP Pump Drives
73-3037	CA-12 Pump Head 12 Channel for BVP/MCP Pump Drives
73-3052	Replacement CA Cassette, Click 'n' Go

MS Multi-Channel Pump Heads for MCP & BVP Pump Drives

73-3030

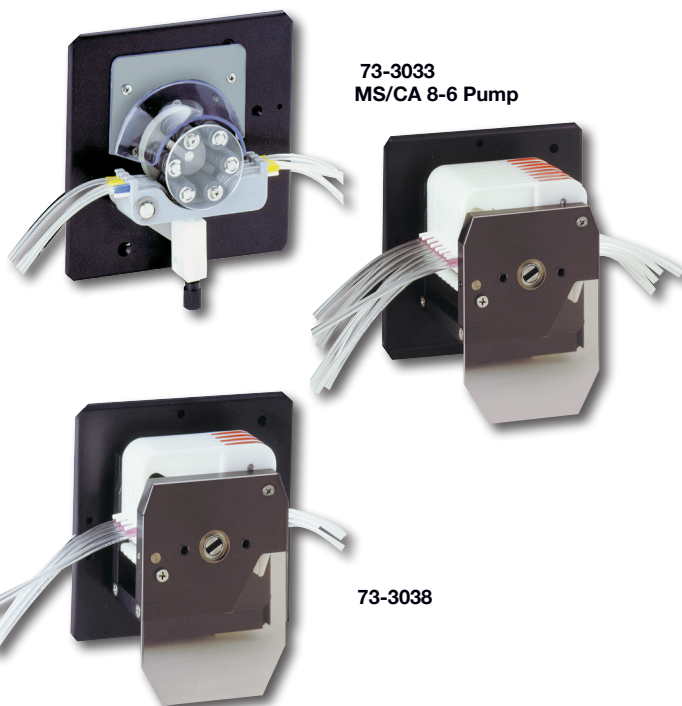

73-3033
MS/CA 8-6 Pump

73-3038

MS-3 PUMP HEAD

- Ideal for sensitive substances requiring a gentle pressure setting
- Uses spring-loaded tube bed set
- Transparent protection cover for easy monitoring of the pump head
- 0.002 to 100 ml/min flow rates
- Uses 3-stop collared tubing, 0.13 to 3.17 mm ID, see page 80
- Back pressure has max of 1.5 bar (22 PSI)

MS/CA 4-12 PUMP HEAD

- MS/CA Click 'n' Go Cassettes are included
- 12 Rollers for extremely low pulsation
- Each channel can take different tube sizes
- Easy and rapid tube change-over; even while pump is running
- 0.001 to 57 ml/min flow rates
- Uses 3-stop collared tubing, 0.13 to 3.17 mm ID, see page 80
- Back pressure has maximum of 1.0 bar (14.5 PSI)

MS/CA 8-6 PUMP HEAD

- MS/CA Click 'n' Go Cassettes are included
- Each channel can take different tube sizes
- Easy and rapid tube change-over; even while pump is running
- 6 rollers
- 0.002 to 100 ml/min Flow Rates
- Uses 3-stop collared tubing, 0.13 to 3.17 mm ID, see page 80
- Back pressure has maximum of 1.0 bar (14.5 PSI)

MS and MS/CA Cassettes Flow Rate Range

3-Stop Collared Tubing ID mm	MS-3 3 Channels 73-3030 Flow Rates ml/min per Channel		MS/CA 4-12 4, 8, 12 or 16 Channels 73-3038 Flow Rates ml/min per Channel		MS/CA 8-6 8, 16, or 24 Channels 73-3033 Flow Rates ml/min per Channel	
	Min.	Max.	Min.	Max.	Min.	Max.
0.13	0.002	0.4	0.001	0.22	0.002	0.33
0.19	0.003	0.73	0.003	0.51	0.003	0.67
0.25	0.005	1.2	0.004	0.91	0.005	1.1
0.38	0.011	2.6	0.009	2.1	0.011	2.6
0.44	0.014	3.4	0.012	2.8	0.014	3.5
0.51	0.019	4.5	0.016	3.8	0.019	4.6
0.57	0.023	5.5	0.019	4.7	0.024	5.7
0.64	0.029	6.9	0.024	5.8	0.03	7.2
0.76	0.04	9.6	0.033	8.0	0.042	10
0.89	0.053	13	0.044	11	0.057	14
0.95	0.06	14	0.050	12	0.064	15
1.02	0.69	17	0.056	13	0.073	18
1.09	0.078	19	0.063	15	0.083	20
1.14	0.084	20	0.067	16	0.090	22
1.22	0.10	23	0.075	18	0.10	24
1.3	0.11	26	0.083	20	0.11	27
1.42	0.12	30	0.094	23	0.13	32
1.52	0.14	34	0.10	25	0.15	36
1.65	0.16	39	0.12	28	0.17	42
1.75	0.18	42	0.13	30	0.19	46
1.85	0.19	47	0.13	32	0.21	50
2.06	0.23	55	0.15	37	0.25	59
2.29	0.27	65	0.17	41	0.29	69
2.54	0.32	76	0.19	46	0.33	79
2.79	0.36	87	0.21	52	0.37	89
3.17	0.42	100	0.24	57	0.43	100

*Note: Approximate values: determined with water at 22°C, no differential pressure, with Tygon® Tubing

Order # Product

73-3046	3V Tube Bed Set for SB Pump Head
73-3033	MS/CA 8-6 Pump Head for BVP/MCP Pump Drives

Click 'n' Go Cassettes

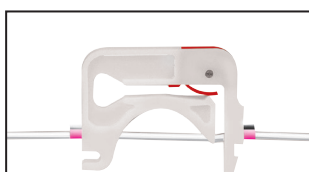

Order #	Product
73-3054	MS/CA Cassette, Click 'n' Go
73-3052	CA Cassette, Click 'n' Go
73-3303	Spare POM-C Adaptor for CA Cassettes

Pressure Lever Cassettes

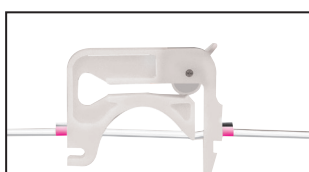

Order #	Product
73-3055	MS/CA Cassette, Pressure Lever
73-3053	CA Cassette, Click 'n' Go
73-3303	Spare POM-C Adaptor for CA Cassettes

Foot Switches



Foot switches provide the start/stop signal required for the pump. This accessory is very practical for use with dispensing systems such as those required for filling tubes or bottles.

Order #	Product
73-3048	Foot Switch for MCP IP, IPC, IP-N, IPC-N
73-3049	Foot Switch for BVP and REGLO Analog Pumps
73-3050	Foot Switch for REGLO Digital Pumps
73-3051	Foot Switch for Ecoline Pumps

Rotors for Ecoline VC-280 and VC-380 Pumps



Order #	Product
73-3114	Rotor, 3 Rollers, Black, Accepts 2.4 mm Tubing Wall Thickness
73-3115	Rotor, 2 Rollers, Black, Accepts 2.4 mm Tubing Wall Thickness
73-3116	Rotor, 2 Rollers, Red, Accepts 1.6 mm Tubing Wall Thickness
73-3117	Rotor, 3 Rollers, Red, Accepts 1.6 mm Tubing Wall Thickness

Pump Accessories

PUMP MODEL	FOOTSWITCH #	CASSETTE TYPE*	ORDER #
REGLO Digital	73-3050	MS/CA CNG	73-3054
REGLO Analog	73-3049	MS/CA CNG	73-3054
Ecoline VC-MS/CA8-6	73-3051	MS/CA CNG	73-3054
Ecoline VC-MS/CA4-12	73-3051	MS/CA CNG	73-3054
Ecoline VC-280, VC-380	73-3051	Exchangeable Rotors	
Ecoline VC-360	73-3051	N/A	-
IP, IP-N	73-3048	CA CNG	73-3052
IPC, IPC-N	73-3048	CA CNG	73-3052
MCP	73-3048	Depends on pump head	
BVP	73-3049	Depends on pump head	

Pump Tubing

3-Stop Collared Pump Tubing for MS/CA Cassettes

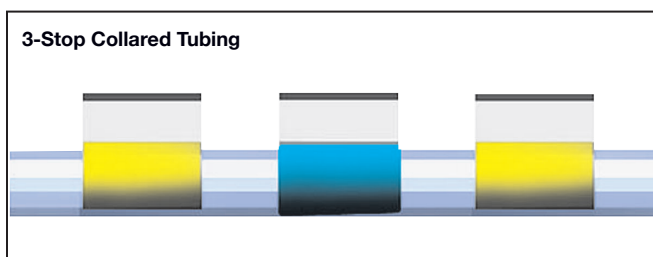

This 3-stop collared tubing is for use with the REGLO Pumps and other pumps. Each length of E-Lab tubing measures 381 mm (15 in), each length of E-LFL, Silicone & BPT tubing measures 406 mm (16 in). Either 12 or 6 lengths are supplied per package. Select your required tubing size and tubing material from the chart below. The distance between the collars is 73 mm (2.9 in). The tubing is available in four different materials. Select the material based on your application.

3-Stop Collared Tubing is required for the following:

- Pumps
 - Ecoline VC-MS/CA4-12 and VC-MS/CA8-6, see page 68
 - All REGLO Digital, see page 66
 - All REGLO Analog, see page 65
- Pump Heads
 - MS-3, see page 78
 - MS/CA 4-12, see page 78
 - MS/CA 8-6, see page 78

3-Stop Collared Pump Tubing					
AME #	TUBING ID	Color Code	Tygon® E-Lab ORDER #	Tygon® E-LFL ORDER #	PharMed® ORDER #
00	0.13 mm	orange-black	73-1816	–	–
02	0.25 mm	orange-blue	73-1818	–	73-3175
03	0.38 mm	orange-green	73-1819	–	–
04	0.44 mm	green-yellow	73-1820	–	–
05	0.51 mm	orange-yellow	73-1821	–	–
06	0.57 mm	white-yellow	73-1822	–	–
07	0.64 mm	orange-white	73-1823	–	–
08	0.76 mm	black-black	73-1824	–	–
09	0.89 mm	orange-orange	73-1825	–	73-3180
10	0.95 mm	white-black	73-1826	–	–
11	1.02 mm	white-white	73-1827	73-3220	73-3181
12	1.09 mm	white-red	73-1828	–	–
13	1.14 mm	red-red	73-1829	–	73-3182
14	1.22 mm	red-grey	73-0126	–	–
15	1.3 mm	grey-grey	73-1830	–	73-3183
16	1.42 mm	yellow-yellow	73-1831	73-3223	73-3184
17	1.52 mm	yellow-blue	73-1832	73-3224	73-3185
18	1.65 mm	blue-blue	73-1833	73-3225	73-3186
19	1.75 mm	blue-green	73-1834	–	–
20	1.85 mm	green-green	73-1835	–	73-3187
21	2.06 mm	purple-purple	73-1836	73-3227	73-3188
22	2.29 mm	purple-black	73-1837	73-3228	73-3189
23	2.54 mm	purple-orange	73-1838	–	73-3190
24	2.79 mm	purple-white	73-0155	73-3230	73-3191
25	3.17 mm	black-white	73-1839	–	–
Pack Size			12 pieces	12 pieces	12 pieces

Pump Tubing

2-Stop Tygon® Pump Tubing for CA Cassettes & Harvard Peristaltic Pump

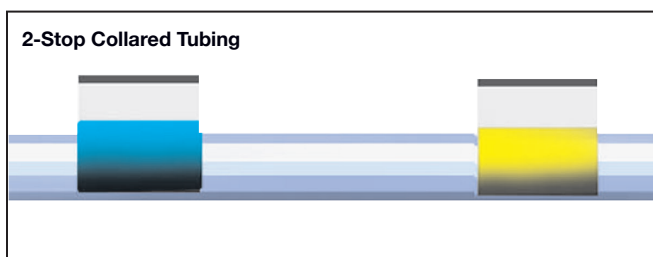

2-Stop Collared Tubing is required for the following:

- Harvard Peristaltic Pump P-230, see page 61
- Pumps
 - IP, IPC, IP-N, IPC-N, see page 71
- Pump Heads
 - CA-4, see page 77
 - CA-8, see page 77
 - CA-12, see page 77

This is 2-stop collared tubing. Each length of tubing measures 406 mm (16 in). Either 12 or 6 lengths are supplied per package. Select your required tubing size and tubing material from the chart below. The distance between the collars is 153 mm (6.1 in). The tubing is available in four different materials. Select the material based on your application.

2-Stop Collared Pump Tubing					
ENE #	Tubing ID	Color Code	Tygon® E-LAB ORDER #	Tygon® LFL ORDER #	PharMed® BPT ORDER #
00	0.13 mm	orange-black	73-3174	–	–
01	0.19 mm	orange-red	73-1840	–	–
02	0.25 mm	orange-blue	73-1841	–	73-3192
03	0.38 mm	orange-green	73-1842	–	73-3193
05	0.51 mm	orange-yellow	73-1844	–	73-3194
07	0.64 mm	orange-white	–	73-3234	–
08	0.76 mm	black-black	73-1847	–	73-3196
09	0.89mm	orange-orange	73-1848	–	73-3197
10	0.95 mm	white-black	73-1849	–	–
11	1.02 mm	white-white	73-1850	73-3237	–
12	1.09 mm	white-red	73-1851	–	–
13	1.14 mm	red-red	73-1852	–	–
14	1.22 mm	red-grey	73-1853	–	–
15	1.3 mm	grey-grey	73-1854	–	73-3200
16	1.42 mm	yellow-yellow	73-1855	–	–
17	1.52 mm	yellow-blue	73-1856	–	73-3202
18	1.65 mm	blue-blue	73-1857	73-3242	–
19	1.75 mm	blue-green	73-1858	–	–
20	1.85 mm	green-green	73-1859	–	–
21	2.06 mm	purple-purple	73-1860	73-3244	–
22	2.29 mm	purple-black	73-1861	–	–
23	2.54 mm	purple-orange	73-1862	–	–
24	2.79 mm	purple-white	73-1863	73-3247	–
25	3.17 mm	black-white	73-1864	–	–
Pack Size			12 pieces	12 pieces	12 pieces

Pump Tubing

3-Stop Tubing for the Harvard Peristaltic Pump P-70

Harvard Peristaltic Pumps P-70 3-Stop Tubing						
Tube Bore mm (in)	Color Code	Max Flow Rate (ml/min)				Connector ² Size
		8-Roller	Silicone (pkg. of 6)	Marpren (pkg. of 6)	PVC (pkg. of 6)	Gauge/Barb Size
0.13 mm (0.005 in)	Orange/Black	0.15	–	–	72-0653	32 g
0.19 mm (0.007 in)	Orange/Red	0.32	–	–	72-0654	31 g
0.25 mm (0.010 in)	Orange/Blue	0.56	–	72-0621	72-0655	28 g
0.38 mm (0.015 in)	Orange/Green	1.30	–	–	72-0656	25 g
0.50 mm (0.020 in)	Orange/Yellow	2.25	–	–	72-0657	23 g
0.63 mm (0.025 in)	Orange/White	3.57	72-0638	–	72-0658	22 g
0.76 mm (0.030 in)	Black/Black	5.19	72-0639	–	72-0659	20 g
0.88 mm (0.035 in)	Orange/Orange	6.96	–	–	72-0660	19 g
1.02 mm (0.040 in)	White/White	9.36	72-0641	–	–	18 g
1.14 mm (0.045 in)	Red/Red	11.69	–	–	72-0662	1/16 inch
1.29 mm (0.050 in)	Gray/Gray	14.96	–	–	–	1/16 inch
1.42 mm (0.055 in)	Yellow/Yellow	18.13	72-0644	–	72-0664	1/16 inch
1.47 mm (0.058 in)	Translucent	19.43	–	–	–	1/16 inch
1.52 mm (0.060 in)	Yellow/Blue	20.78	72-0646	72-0631	72-0665	1/16 inch
1.65 mm (0.065 in)	Blue/Blue	24.48	72-0647	–	72-0666	1/16 inch
1.85 mm (0.070 in)	Green/Green	30.78	72-0648	–	72-0667	3/32 inch
2.05 mm (0.080 in)	Purple/Purple	37.79	72-0649	–	–	3/32 inch
2.38 mm (0.095 in)	Purple/Black	50.94	72-0650	–	72-0669	3/32 inch
2.54 mm (0.100 in)	Purple/Orange	58.02	–	–	–	1/8 inch
2.79 mm (0.110 in)	Purple/White	70.00	72-0652	72-0637	72-0671	1/8 inch

² Size of hypodermic tubing (g. gauge) or barbed connector (in.) needed. Connection with tubing segment requires hypodermic tubing or barbed connector; see page 101 to 106.

Tygon® Standard Pump Tubing

This tubing is offered in 4 varieties. Select the tubing material based on your application. It is supplied in either 7.5 or 15 meter lengths.

Standard Tubing is required for the following:

- **Pumps**
 - For use with Harvard Peristaltic Pump P-1500
 - Ecoline VC-280
 - Ecoline VC-380
 - Ecoline VC-360
 - Ecoline VC-Easy-Load
- **Pump Heads**
 - PRO-280
 - PRO-380
 - PRO-281
 - PRO-381
 - 380AD
 - SB-2V
 - SB-3V

Standard Pump Tubing

TUBING ID	WALL THICKNESS	Tygon® ST R-3603	Tygon® E-LFL	Platinum Cured Silicone	PharMed® BPT
		ORDER #	ORDER #	ORDER #	ORDER #
Harvard Peristaltic Pump P-1500 can only use standard tubing with a wall thickness of 1.6 mm, see page 60.					
0.8 mm	1.6 mm	73-1806	–	–	72-0958
1.6 mm	1.6 mm	72-1016	72-0983	73-3255	72-0960
3.2 mm	1.6 mm	72-1020	72-0984	73-3256	72-0963
4 mm	1.6 mm	72-1022	–	–	–
4.8 mm	1.6 mm	72-1024	72-0985	73-3257	72-0964
6.4 mm	1.6 mm	72-1026	72-0986	73-3259	72-0965
8 mm	1.6 mm	72-1027	72-0988	73-3261	72-0967
Length Supplied		15 m (49 ft)	7.5 m (24.6 ft)	15 m (49 ft)	7.5 m (24.6 ft)

Extension Tubing & Connectors

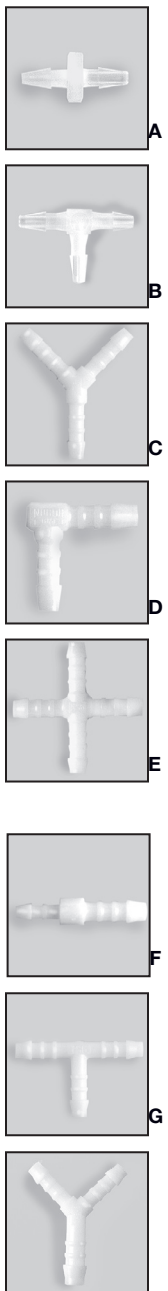

Standard Tube Connectors, Plastic

The Plastic Tube Connectors are designed to assist you in quickly and easily making connections between 2 and 3-Stop Collared Tubing of similar sizes. There are five different connector types available. They are supplied non-sterile in packages of 10.

	Straight Connector (A)	T-Connector (B)	Y-Connector (C)	Angle Connector (D)
Tube ID	ORDER #	ORDER #	ORDER #	ORDER #
1.5 mm	72-9262	72-9275	-	72-9306
2.5 mm	72-9263	-	-	-
3.0 mm	72-9264	-	72-9295	-
4.0 mm	72-9265	-	72-9296	-
5.0 mm	-	-	72-9297	-
6.0 mm	-	-	72-9298	-
8.0 mm	72-9268	72-9287	72-9299	72-9312
19.0 mm	-	72-9294	-	-

Plastic, Reducer Tube Connectors

The Plastic Tube Connectors are designed to assist you in quickly and easily making connections between 2 and 3-Stop Collared Tubing of dissimilar sizes. There are three different connector types available. They are supplied non-sterile in packages of 10.

Straight Connector (F)			Y-Connector (H)		
ORDER #	Tube ID	Tube ID	ORDER #	Tube ID	Tube ID
72-9324	1.5 mm	3.0 mm			
72-9329	6.0 mm	8.0 mm			
72-9331	8.0 mm	10.0 mm			

Extension Tubing & Connectors (continued)

Extension Tubing for 2 and 3-Stop Collared Tubing

Extension Tubing is required for extending the tube line on the suction and discharge side of 2 and 3-stop tubing.

Tube ID (mm)	Tygon® E-Lab (1 Roll of 30 m)	Silicone Peroxide (1 Roll of 15 m)
	ORDER #	ORDER #
0.13	72-9174	-
0.19	-	-
0.25	-	-
0.38	72-9177	-
0.44	-	-
0.51	-	-
0.57	72-9180	-
0.64	-	-
0.76	72-9182	72-9241
0.89	72-9183	-
0.95	-	-
1.02	-	72-9243
1.09	-	-
1.14	72-9187	72-9244
1.22	72-9188	-
1.30	72-9189	72-9245
1.42	72-9190	-
1.52	72-9191	-
1.65	72-9192	-
1.85	-	-
2.06	72-9195	-
2.29	72-9196	-
2.54	-	-
2.79	72-9198	-
3.17	72-9199	-

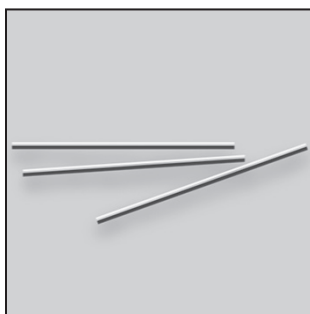

Stainless Steel Standard Tube Connectors

The Stainless Steel Tube Connectors are designed to assist you in quickly and easily making connections between 2 and 3-Stop Collared Tubing of similar sizes. They are supplied non-sterile in packages of 6.

ORDER #	Tube ID (mm)	Tube OD (mm)	Connector Length (mm)
72-9254	0.30	0.63	15
72-9257	0.84	1.27	11
72-9258	0.84	1.27	16
72-9259	0.30	0.63	25
72-9260	0.58	0.90	25

Centrifugal Pump for Blood and Cell Containing Fluids

Centrifugal Pump



KEY FEATURES

- Speed range: 36 - 3600 rpm
- Low hemolysis
- Flow rates up to 10 L/min.
- Little to no pulsation
- Pump heads interchangeable without tool
- Digital pump control interface
- Robust construction for long life
- Analog interface for remote control

The centrifugal pump is specifically designed for pumping blood and/or erythrocyte suspension solutions in the physiological or pharmacological laboratory.

A complete setup consists of the digital pump drive with centrifugal head mounting plate (73-5157) and a centrifugal pump head (73-5173). The pump head is hermetically sealed. Flow rates are up to 10 L/min. The perfusion circuit resistance will limit the flow rate that can be achieved. See the pressure flow graph for more details. A priming circuit is supplied with the pump along with an instruction manual for care and use. The pump can be coupled with an APT300 Pressure Transducer, TAM-D Transducer Amplifier, SCP Pump Controller, PLUGSYS housing and Controller Connection Cable to perform constant pressure perfusion.

Centrifugal Pump Specifications

Pump Drive	
SPEED	3 to 3600 rpm,
MAINS CONNECTION	115 V - 230 V (50/60 Hz)
ANALOG INTERFACE	Speed control 0–5 V or 0–10 V or 0–20 mA or 4–20 mA, start/stop (TTL contacts)
PROTECTION RATING	IP 33 per IEC 60529
OPERATING CONDITIONS	+5 to +40°C rel. humidity 80% max.
DIMENSIONS, H x W x D	10.5 in x 8 in x 8 in (267 x 203 x 203 mm)
WEIGHT	7 kg (15.4 lb) without pump head
AP40 Centrifugal Pump Heads	
MANUFACTURER	Medtronic
PUMP TECHNOLOGIES	Centrifugal
MAXIMUM FLOW RATE	10 L/min at 80 mmHg Backpressure 8.5 L/min at 150 mmHg Backpressure
PULSATION	no
PRIMING VOLUME	40 ml
INLET/OUTLET ID	9.5 mm

Order # Product

73-5157	Centrifugal Pump Drive, 110V – 240 VAC
73-5173	Centrifugal Pump Head AP40
72-4621	Tygon® E-3603 Tubing, 15.2 m (50 ft) Length, 9.5 mm (3/8 in) ID, 12.7 mm (1/2 in) OD
73-4759	Connection Cable SCP to 25 PIN D-SUB (DB-25) for MFLX L/S, L/S DIGITAL, REGLO and HSE Centrifugal Pump Drives

Note: Pump Drive and Pump Head must be purchased separately.

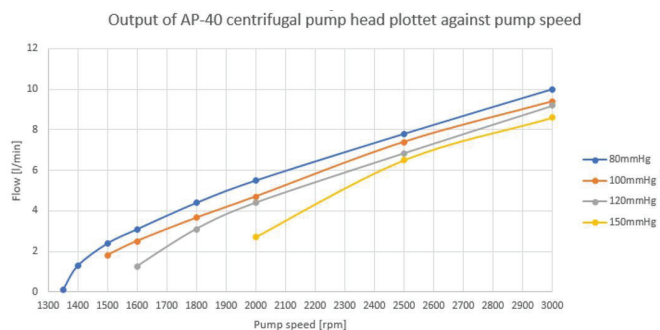

Harvard Apparatus Pulsatile Blood Pumps

Pulsatile Blood Pump

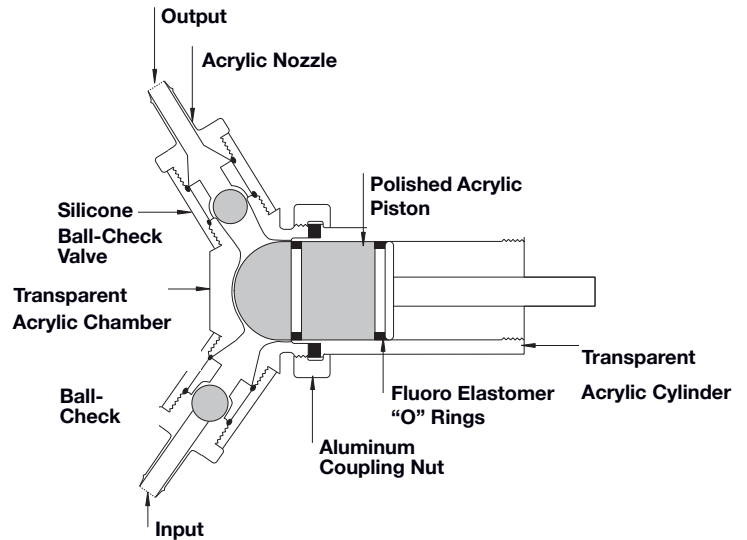

KEY FEATURES

- Pulsatile output truly simulates the ventricular action of the heart
- Minimal hemolysis
- Models for mice to large animals
- Ideal for moving emulsions, suspensions, and non-Newtonian fluids such as blood

If you are performing cardiovascular work, this is the pump for you. It truly simulates the pumping action of the heart. It features silicone rubber-covered heart-type ball valves and smooth flow paths which minimize hemolysis. Only inert materials like silicone rubber, acrylic plastic, and PTFE contact the fluid. The pumping head is easy to take apart and reassemble and can be sterilized.

Outstanding Performance

The pulsatile output closely simulates the ventricular action of the heart. This action provides physiological advantages in blood flow for perfusion in cardiovascular and haemodynamic studies. It is ideal for isolated organ perfusion, whole body perfusion, blood transfers, hydration/dehydration procedures, and blood cellular

profile studies.

Pump Mechanism

A positive piston actuator and ball check valves provide the proportioning action. The product of stroke rate times stroke volume is an accurate indicator of the flow rate. Positive piston action prevents changes in flow rates, regardless of variations in resistance or back pressure. The piston always travels to the end of the ejection stroke, independent of the volume pumped. The Pump completely empties at each cycle.

Harvard Apparatus now offers the pumping head in polysulfone which is autoclavable. The standard models use acrylic which must be sterilized using ethylene oxide or other methods. This new material makes it much easier to maintain sterility.

Harvard Apparatus now also offers a new control method for the blood pumps. Now the pump can be controlled from an external voltage source; 0 to 10 volt DC signal can be used to control the stroke rate and phasing of the pump. External control interfaces the blood pump with a computer to generate advanced cardiovascular waveforms and more control over pressure curves. Please call for more information.

Harvard Apparatus Pulsatile Blood Pump Specifications

	Mice/Rats: Model 1407	Rabbits: Model 1405	Dogs/Monkeys: Model 1421	Large Animals; Hemody- namic Studies: Model 1423
STROKE VOLUME, ADJUST- ABLE	0.05 to 1.0 ml	0.5 to 10 ml	4 to 30 ml	15 to 100 ml
RATE, STROKE/MIN.	20 to 200	20 to 200	20 to 200	10 to 100
MINUTE VOLUME, STROKE VOL. x RATE	1 to 200 ml	10 to 2,000 ml	80 to 6,000 ml	150 to 10,000 ml
PHASING	Fixed Phase	Fixed Phase	Adjustable Phase	Adjustable Phase
SYSTOLE/DIASTOLE RATIO	35% systole,	35% systole,	35% to 50%	35% to 50%
TUBE ID	8 mm (0.31 in)	8 mm (0.31 in)	11 mm (0.437 in)	14 mm (0.551 in)
DIMENSIONS, H x W x D	312 x 156 x 250 mm (12.3 x 6.1 x 9.9 in)	312 x 156 x 250 mm (12.3 x 6.1 x 9.9 in)	500 x 212 x 337 mm (19.7 x 8.4 x 13.4 in)	500 x 212 x 337 mm (19.7 x 8.4 x 13.4 in)
WEIGHT	7.3 kg (16 lb)	7.3 kg (16 lb)	13.6 kg (30 lb)	14.5 kg (32 lb)
VOLTAGE	115 VAC, 50/60 Hz or 230 VAC, 50/60 Hz UK and EU Models	115 VAC, 50/60 Hz or 230 VAC, 50/60 Hz UK and EU Models	115 VAC, 50/60 Hz or 230 VAC, 50/60 Hz UK and EU Models	115 VAC, 50/60 Hz or 230 VAC, 50/60 Hz UK and EU Models
ORDER #	52-9552	55-1838	55-3321	55-3305

Harvard Apparatus Pulsatile Blood Pumps (continued)

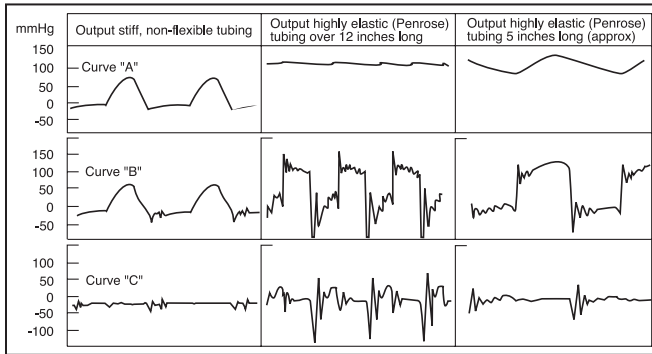

Pressure Curves

The shape of the output pressure curve is a function of both the pump action and the characteristics of the external system on the output valve side. The following set of curves were obtained with Model 1421, using water as the pumped medium. In the tests, "Sanborn" pressure transducers were inserted in three places, and continuous records obtained under varying conditions.

- Curve A** Pressure just beyond the output valve
- Curve B** Pressure within the pump chamber
- Curve C** Pressure just before the intake valve

By variation of parameters involved (peripheral resistance, stroke rate, stroke volume and phase ratio), an infinite number of output flow characteristics can be obtained.

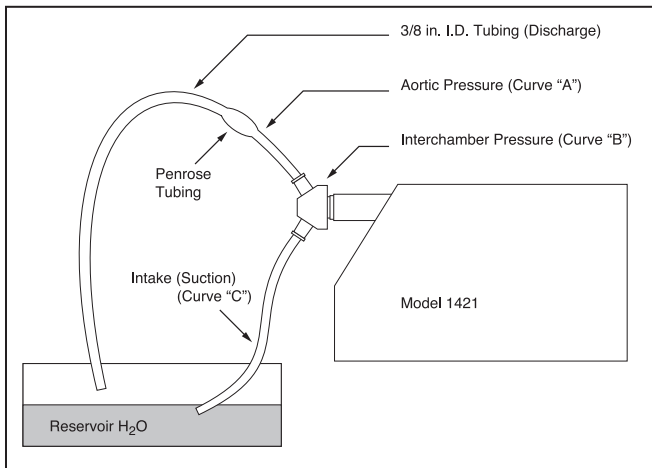

Hemolysis Test Conditions Models for Dog/Monkey (55-5321) and Large Animals (55-3305)

Hemolysis ranged from 0.114 mg% to 0.29 mg% per pass through the various pumps, with an error of $\pm 10\%$.

To put these results in perspective, most physiological perfusions are run with flow rates and total blood primes, such that the number of passes through the pump will range from about 1/4 to 3/4 per minute. Assuming one pass in two minutes and no physiological removal of the products of hemolysis, then hemolysis rates would range from 3.4 mg% to 8.7 mg% per hour of pump use.

In these studies a reservoir of 500-800 cc of fresh dog blood was used, connected to the pump by 3/8" PVC tubing. Samples at room temperature were taken at 15 and 30 minute intervals for 4 to 5 hours. Samples were spun down and hemolysis measured immediately using the method of Flink and Watson. Since the rate of hemolysis depends on the amount of blood in the system and the flow rate, the results are reported as mg% per pass. The flow rate divided by the volume of blood in the system determines the number of passes through the pump per minute.

*Pressure and Flow Curves Using Harvard Pulsatile Blood Pump for Dogs/Monkeys in Isolated Perfusion of Left Lower Lobe of Dog Lung**

Pa Pulmonary Artery Pressure
Pv Pulmonary Venous Pressure
Qpa Pulmonary Artery Blood Flow

Instrumentation:
Pressure Statham
Flow Biotronex Electromagnetic Flowmeter
Recording Electronics for Medicine

*Note: The above data is supplied through the courtesy of Cardiorespiratory laboratory Columbia-Presbyterian Medical Center New York, New York, Dr. Alfred P. Fishman, Director.

Priming Kit, Compression Fittings and PEEK Tubing

Priming Kit

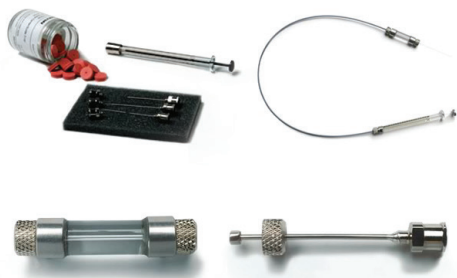

The Priming Kit provides the necessary tools to ensure that the syringe and needle connection is completely primed. Trapped air can cause inaccurate dispenses and standard priming techniques are not sufficient when using capillary tubing. The glass capillary tubing traps a large volume of liquid that can only be overcome by using the priming kit. The Priming Kit contains one 250 µl Syringe, one 6 pack of 30 gauge needles, and one pack of septa.

The 1 mm RN Compression Fitting is designed to attach pulled glass pipettes directly to a small hub RN connection. The RN nut compresses the conical PFA ferrule into the PEEK cup ferrule creating a seal between the syringe barrel and the glass capillary tubing. The connection requires no modifications to the glass capillary tubing.

The 1/16 in RN Compression Fitting is designed to attach 1/16 in PEEK tubing directly to a small hub RN connection. Tightening the RN nut compresses the conical PFA ferrule into the PEEK cup ferrule creating a seal between the syringe barrel and the PEEK tubing. The RN Compression Fittings consist of one large bore RN nut, 5 PFA ferrules and 5 PEEK cup ferrules. They are compatible with 2.5-100 µl RN syringes.

The Dual Small Hub RN Coupler is constructed from model 1702 glass with a small hub RN termination on either end. It uses a standard glass size for compatibility with most stereotaxic instrumentation. The coupler is ideal for remotely connecting a syringe to a needle via PEEK tubing. It is also used with the Luer to RN adaptor for connection of custom needles to a 7000 series syringe. The Dual RN Coupler consists of two large bore RN nuts, and one dual RN barrel.

The Luer to Small Hub RN Adaptor consists of a Metal Luer Lock Hub and a Small Removable Needle Hub combined in a single needle. The Luer to RN Adaptor and the Dual RN Coupler can be used to connect a 7000 series syringe to any Small Hub Removable Needle or to a Pulled Glass Pipette. The Adaptor creates a rigid connection between the syringe and the needle as well as compatibility with stereotaxic instrumentation. The Luer to RN Adaptor consists of one RN to Luer Needle and a sealing ferrule

Order #	Model	Product
72-9354	PRMKIT	Priming Kit
72-9353	55750-01	RN Compression Fitting 1 mm
72-9376	55751-01	RN Compression Fitting 1/16 in
72-9377	55752-01	Dual Small Hub RN Coupler
72-9378	55753-01	Luer to Small Hub RN Adaptor

PEEK Semi-Flexible Tubing

PEEK semi-rigid tubing is manufactured from a unique, high temperature engineering thermoplastic that is suitable for a wide range of demanding applications. Designed to withstand high pressure and temperature levels, PEEK Tubing resists even the harshest environmental conditions. Semi-rigid PEEK tubing is insoluble in virtually all organic and inorganic solvents as well as having good dielectric properties. It can be cut to length, accepts pressure fittings and readily stands up to shock, abrasion and impacts. PEEK can be sterilized with Gamma, ETO and is autoclavable.

Order #	Product
72-5332	PEEK Semi-Flexible Tubing, 0.006 in ID x 0.062 in OD x 0.028 in Wall Thickness, 5 ft
72-5333	PEEK Semi-Flexible Tubing, 0.010 in ID x 0.062 in OD x 0.026 in Wall Thickness, 5 ft
72-5334	PEEK Semi-Flexible Tubing, 0.020 in ID x 0.062 in OD x 0.021 in Wall Thickness, 5 ft
72-5335	PEEK Semi-Flexible Tubing, 0.030 in ID x 0.062 in OD x 0.016 in Wall Thickness, 5 ft
75-1030	0.02"(.5mm) ID, 1/16"OD PFA tubing, 50ft
75-1031	0.03"(.76mm) ID, 1/16"OD PFA tubing, 50ft
75-1032	0.04"(1mm) ID, 1/16"OD PFA tubing, 50ft

Order #	Product
FOR 1/16" OD RIGID TUBING:	
72-2851	Union for 1/16" tubing, 2x ferrules & 2x nuts PEEK, (complete set)
72-2857	Ferrule for 1/16", ETFE (10 pack)
512-1316	Nut for 1/16", PEEK
FOR 1/8" OD RIGID TUBING:	
72-2852	Union for 1/8", 2x ferrules & 2x nuts PEEK, (complete set)
72-2859	Ferrule for 1/8", ETFE (10 pack)
72-2864	Nut for 1/8", PEEK
72-2867	Nut for 1/8", Polypropylene
ADAPTERS:	
5121-303	Female Luer Lock to male ¼-28 (external thread) tefzel
5121-304	Male Luer Lock to male ¼-28 (external thread)
75-0430	Female Luer Lock to female ¼-28 (internal thread) tefzel
72-2855	¼-28 Union, Delrin (any size tubing)
72-2856	¼-28 Union, Polypropylene (any size tubing)

Laboratory Tubing

Harvard Apparatus offers an extensive selection of tubing and connectors for all of your laboratory application needs. We offer a wide range of tubing and connectors for virtually every bioscience application. Tubing is available in a variety of materials and dimensions. Sizes in addition to that which is presented here are listed on our Website or contact our technical support for a complete list of available tubing. Tubing connectors with barbed or Luer ends come in several different material types to suit a wide range of research applications. In addition, many valves and manifolds are now available to simplify tubing connections and flow control even in the most demanding experimental protocols. Tubing connector kits feature a selection of similarly sized connectors in one convenient container. All the individual kit components can be reordered.

Tygon® Long Flex Life Pump Tubing (E-LFL)

Tygon® E-LFL



KEY FEATURES

- Longest flex life of any clear Tygon® tubing
- Extremely low particulate spallation
- Broad chemical resistance
- Meets USP Class VI and FDA criteria

Specifically developed for bulk transfer applications, Tygon® Long Flex Life Tubing offers the longest peristaltic pump life of any clear Tygon® tubing formulation.

Crystal-clear Tygon® Long Flex Life Pump Tubing is formulated specifically for use in peristaltic pump applications. With its superior flex life characteristics, manufacturing processes can be simplified by reducing production downtime due to pump tubing failure.

The excellent wear properties of Tygon® Long Flex Life Pump Tubing also lead to a reduction of particulate spallation. This feature limits the risk of sensitive-fluid contamination critical to the pharmaceutical, cosmetic, food and beverage industries.

Non-aging characteristics and broad chemical resistance provide users with versatility in use for a wide variety of applications. Safe and non-toxic Tygon® Long Flex Life Pump Tubing can be produced in up to a 6 inch ID, making it the ideal choice in bulk

Tygon® Long Flex Life Pump Tubing (E-LFL)

ORDER #	ID (MM)	OD (MM)	ID (IN)	OD (IN)	length (m)	length (ft)
72-0983	1.6	4.8	1/16	3/16	7.6	25
72-0984	3.2	6.4	1/8	1/4	7.6	25
72-0985	4.8	7.9	3/16	5/16	7.6	25
72-0986	6.4	9.5	1/4	3/8	7.6	25
72-0988	7.9	11.1	5/16	7/16	7.6	25

* Note: Higher durometer values correlate with stiffer less flexible tubing.

Tygon® Norprene® Tubing

Tygon® Norprene®



KEY FEATURES

- Best choice for long term peristaltic pump accuracy
- Repeatably autoclavable
- Wide temp. range -60° to 275°F
- Opaque

Formulated to withstand high temperatures frequently, Norprene® Tubing will outlast and outperform virtually all other food grade tubings. Even following extended exposure to heat and ozone, Norprene® Tubing will not crack or deteriorate which is common when using traditional rubber tubings.

Extremely flexible, Norprene® Tubing resists kinks and retains its shape while installing quickly and easily. Its excellent flexural fatigue resistance makes it the absolute best choice for use in peristaltic pumps.

Repeatedly autoclavable, Norprene® Tubing can be steam cleaned in place, eliminating the need for frequent tubing replacement. When harsh sanitizing solutions are used, it exhibits exceptional chemical resistance and is entirely unaffected by a wide variety of

Tygon® Norprene® Tubing

ORDER #	ID (MM)	OD (MM)	ID (IN)	OD (IN)	length (m)	length (ft)
72-0950	6.4	12.7	1/4	1/2	15.2	50
72-0956	19.1	25.4	3/4	1	15.2	50

* Note: Higher durometer values correlate with stiffer less flexible tubing.

Laboratory Tubing (continued)

Tygon® Laboratory Tubing (E-3603)

Tygon® E-3603



KEY FEATURES

- Outstanding chemical resistance
- Lot-to-lot consistency for reproducible results
- Increases productivity in peristaltic pumps -outlasts other clear tubing 2 to 1

The most consistently reliable tubing for the transfer of liquids and gases, Tygon® Laboratory Tubing handles virtually all inorganic chemicals found in today's laboratories. Crystal-clear and flexible, it's non-oxidizing and non-contaminating. Long-lasting and crack-resistant, Tygon® Laboratory Tubing is less permeable than rubber tubing. The glassy-smooth inner bore helps prevent buildup so that cleaning is facilitated. Coils are marked at 1-foot intervals for easy measuring. Autoclavable. Remains flexible at -45°F (-43°C). Durometer hardness: Shore A, 55.*

Tygon® Laboratory Tubing (E-3603)						
ORDER #	ID (MM)	OD (MM)	ID (IN)	OD (IN)	length (m)	length (ft)
72-1014	0.8	2.4	1/32	3/32	15.2	50
72-1015	1.6	3.2	1/16	1/8	15.2	50
72-1016	1.6	4.8	1/16	3/16	15.2	50
72-1017	2.4	4.0	3/32	5/32	15.2	50
72-1018	2.4	5.6	3/32	7/32	15.2	50
72-1019	3.2	4.8	1/8	3/16	15.2	50
72-1020	3.2	6.4	1/8	1/4	15.2	50
72-1021	4.0	5.6	5/32	7/32	15.2	50
72-1022	4.0	7.1	5/32	9/32	15.2	50
72-1023	4.8	6.4	3/16	1/4	15.2	50
72-1024	4.8	7.9	3/16	5/16	15.2	50
72-1026	6.4	9.5	1/4	3/8	15.2	50
72-1027	7.9	11.1	5/16	7/16	15.2	50
72-1028	7.9	14.3	5/16	9/16	15.2	50
72-4621	9.5	12.7	3/8	1/2	15.2	50
72-1029	9.5	14.3	3/8	9/16	15.2	50
72-1030	9.5	15.9	3/8	5/8	15.2	50
72-4622	11.1	14	7/16	9/16	15.2	50
72-1031	11.1	15.9	7/16	5/8	15.2	50
72-1032	11.1	17.5	7/16	11/16	15.2	50
72-1033	12.7	17.5	1/2	11/16	15.2	50
72-1034	12.7	19.1	1/2	3/4	15.2	50
72-1037	15.9	20.6	5/8	13/16	15.2	50
72-1038	15.9	22.2	5/8	7/8	15.2	50
72-1039	17.5	22.2	11/16	7/8	15.2	50
72-1040	19.1	25.4	3/4	1	15.2	50
72-1041	19.1	27.0	3/4	1-1/16	15.2	50

* Note: Higher durometer values correlate with stiffer less flexible tubing.

Tygon® B-44-4X Tubing

Tygon® B-44-4X



KEY FEATURES

- Non-wetting surface permits thorough cleaning and complete drainage
- Smooth, non-porous bore will not trap particulates or promote bacterial growth
- Broad chemical resistance to virtually all non-solvent chemicals. Resistant to harsh alkaline cleaners and sanitizers.
- Excellent alternative to rigid piping systems but still lightweight and flexible enough for easy and quick installation
- Meets FDA, 3-A and NSF criteria

With its smooth, non-porous bore, B-44-4X Tubing ensures a bacteria-free fluid path in a wide variety of processing applications. Offers dependable performance in countless filling, draining, transfer and processing applications. Its smooth, non-porous bore inhibits particle entrapment, promoting a sanitary fluid path by minimizing potential for bacterial growth. It has outstanding resistance to harsh alkaline cleaners and is equally unaffected by commonly used sanitizers. Complete clarity for positive visual inspection and flow control. Autoclavable and Gas (Ethylene Oxide) sterilizable.

Tygon® B-44-4X Tubing						
ORDER #	ID (MM)	OD (MM)	ID (IN)	OD (IN)	length (m)	length (ft)
72-0921	0.8	2.4	1/32	3/32	15.2	50
72-0922	1.6	3.2	1/16	1/8	15.2	50
72-0924	2.4	4.0	3/32	5/32	15.2	50
72-0927	3.2	6.4	1/8	1/4	15.2	50
72-0928	4.0	5.6	5/32	7/32	15.2	50
72-0932	6.4	7.9	1/4	5/16	15.2	50

* Note: Higher durometer values correlate with stiffer less flexible tubing.

Laboratory Tubing (continued)

Tygon® PharMed® Tubing

Tygon® PharMed®



KEY FEATURES

- Outlasts silicone tubing in peristaltic pumps by up to 30 times
- Opaque
- Can be autoclaved repeatedly
- Heat weldable for sterile access in closed systems
- Meets USP Class VI, FDA and NSF criteria

Created with a unique combination of long flex life and biocompatibility, PharMed® Tubing is ideal for life science applications employing peristaltic pumps. PharMed® Tubing is less permeable to gases and vapors than silicone tubing. It is ideal for cell culture, fermentation, synthesis, separation, purification and process monitoring and control. Independent tests show that PharMed® Tubing is safe for use in sensitive cell culture applications. It has very good general chemical resistance and excellent acid, alkali and oxidation resistance. Opaque to visible and UV light, it helps protect sensitive fluids. Continuous service temperature range is -60°F (-51°C) to 275°F (135°C). Durometer hardness: Shore A, 64.*

Tygon® PharMed® Tubing						
ORDER #	ID (MM)	OD (MM)	ID (IN)	OD (IN)	length (m)	length (ft)
72-0957	0.5	3.7	0.020	0.144	7.6	25
72-0958	0.8	4.0	1/32	5/32	7.6	25
72-0959	1.6	3.2	1/16	1/8	7.6	25
72-0960	1.6	4.8	1/16	3/16	7.6	25
72-0961	2.4	5.6	3/32	7/32	7.6	25
72-0962	3.2	4.8	1/8	3/16	7.6	25
72-0963	3.2	6.4	1/8	1/4	7.6	25
72-0964	4.8	7.9	3/16	5/16	7.6	25
72-0965	6.4	9.5	1/4	3/8	7.6	25
72-0967	7.9	11.1	5/16	7/16	7.6	25

* Note: Higher durometer values correlate with stiffer less flexible tubing.

Tygon® Medical/Surgical Tubing (ND100-65)

Tygon® ND100-65



KEY FEATURES

- Crystal clear
- Ideal for blood contact
- Flexible and resilient with established performance in peristaltic pump
- Fully characterized to ISO 10993 and FDA guidelines for biocompatibility
- Meets USP Class VI criteria

Crystal clear Tygon® Medical/ Surgical Tubing provides proven performance in countless medical device applications.

Originally developed for use in cardiac surgery, Tygon® Medical/ Surgical Tubing's consistent quality provides dependable performance in medical device applications. It has been fully tested for biological safety to the ISO 10993 standard.

Tygon® Medical/Surgical Tubing can be sterilized by radiation, ethylene oxide, steam or chemical methods.

Durometer hardness: Shore A, 65.*

Tygon® Medical/Surgical Tubing (ND100-65)						
ORDER #	ID (MM)	OD (MM)	ID (IN)	OD (IN)	length (m)	length (ft)
75-0440	0.8	2.4	1/32	3/32	15.2	50
75-0441	1.6	3.2	1/16	1/8	15.2	50
75-0445	3.2	4.7	1/8	3/16	15.2	50
75-0446	3.2	6.3	1/8	1/4	15.2	50
75-0448	3.9	7.1	5/32	9/32	15.2	50
75-0449	4.7	6.3	3/16	1/4	15.2	50
75-0450	4.7	7.9	3/16	5/16	15.2	50
75-0452	6.3	9.5	1/4	3/8	15.2	50
75-0455	9.5	14.2	3/8	9/16	15.2	50
75-0463	15.8	22.1	5/8	7/8	15.2	50

* Note: Higher durometer values correlate with stiffer less flexible tubing.

Laboratory Tubing (continued)

Tygon® Ultra-Soft Tubing (E-1000)

Tygon® E-1000



KEY FEATURES

- Ultra-soft and flexible
- Performs well at low temperatures (to -100°F)
- Excellent for use in low-torque pump applications

Tygon® Ultra-Soft Tubing provides unmatched flexibility and drapability-characteristics beneficial to numerous laboratory set-ups.

Tygon® Ultra-Soft Tubing resists a broad range of aqueous chemicals and provides an excellent alternative to silicone tubing in applications where corrosive chemicals are used. Its minimal resistance to compression permits use in low-torque pump applications including battery driven types. Tygon® Ultra-Soft Tubing stays flexible at temperatures as low as -100°F (-73°C). Its smooth bore facilitates easy cleaning and helps prevent possible buildup. Do not autoclave. Durometer hardness: Shore A, 40.*

Tygon® Ultra-Soft Tubing (E-1000)

ORDER #	ID (MM)	OD (MM)	ID (IN)	OD (IN)	length (m)	length (ft)
72-0998	1.6	4.8	1/16	3/16	15.2	50
72-0999	3.2	6.4	1/8	1/4	15.2	50

* Note: Higher durometer values correlate with stiffer less flexible tubing.

Tygon® Ultra Chemical Resistant Tubing (2375)

Tygon® 2375



KEY FEATURES

- Suitable for most gas anesthesia applications
- Temperature resistant from -60° to 275°F
- Compatible with virtually all common sanitizers and cleaners

After being immersed in aggressive MEK for 16 hours (plus 4 hours drying time), Tygon® Ultra Chemical Resistant Tubing is still clear and flexible while PVC tubing is completely degraded and rendered useless.

Tygon® Ultra Chemical Resistant Tubing offers an unequalled combination of chemical resistance, clarity and flexibility. It is virtually unaffected by acids, bases, ketones, salts and alcohols, fitting the requirements of many applications from acids to hazardous material handling. It's entirely plasticizer-free, eliminating fluid contamination and the premature embrittlement and cracking common with many types of flexible tubing. Its exceptionally smooth inner surface inhibits particulate buildup and reduces the potential for contamination. Do not autoclave.

Tygon® Ultra Chemical Resistant Tubing (2375)

ORDER #	ID (MM)	OD (MM)	ID (IN)	OD (IN)	length (m)	length (ft)
72-4119	1.6	4.8	1/16	3/16	15.2	50
72-4120	3.2	6.4	1/8	1/4	15.2	50

* Note: Higher durometer values correlate with stiffer less flexible tubing.

Laboratory Tubing (continued)

FEP Semi-Flexible Tubing

KEY FEATURES

- Excellent chemical resistance even at extreme temperatures from -348° to 392°F
- UV and ozone resistant
- Low protein adsorption
- FDA compliant/USP Class VI

With excellent resistance to chemicals, ozone and UV radiation, FEP tubing maintains its chemical resistance even at extreme temperatures. Its superior non-stick characteristics ease the transfer of product lowering the incidence of protein binding/absorption. Ideal for the transfer of fluids like synthetic peptides and antibodies whose protein composition must be maintained to exacting tolerances.

FEP Semi-Flexible Tubing						
ORDER #	ID (MM)	OD (MM)	ID (IN)	OD (IN)	length (m)	length (ft)
72-1169	1.6	3.2	1/16	1/8	7.6	50

* Note: Higher durometer values correlate with stiffer less flexible tubing.

PFA Semi-Flexible Tubing

KEY FEATURES

- Excellent chemical resistance
- UV and ozone resistant
- Suitable for a wide range of temperature applications from -320° to 500°F
- FDA compliant/USP Class VI

PFA tubing has better flex life and mechanical characteristics at elevated temperatures versus traditional PTFE tubing. Like FEP tubing it has superior chemical and environmental (UV and Ozone) resistance with a higher working temperature range than FEP. Durometer hardness: Shore D, 60.*

PFA Semi-Flexible Tubing						
ORDER #	ID (MM)	OD (MM)	ID (IN)	OD (IN)	length (m)	length (ft)
72-1136	3.2	4.8	1/8	3/16	7.6	50

* Note: Higher durometer values correlate with stiffer less flexible tubing.

Laboratory Tubing (continued)

Tygon® Fluran® Severe Environment Tubing

Tygon® Fluran®



KEY FEATURES

- Provides continuous service at temperatures up to 400°F (204°C)
- Excellent resistance to corrosive chemicals, oils, fuels and solvents
- Resists ozone, sunlight and weathering
- Opaque black color helps protect light sensitive fluids

Resistant to corrosive chemicals and solvents, Fluran® Severe Environment Tubing is designed to handle the most aggressive solutions at temperatures as high as 400°F.

Made of a proprietary fluoroelastomer, Fluran® Severe Environment Tubing has both the physical and chemical properties that make it ideal for severe environments, such as dry cleaning fluid lines and solvent recovery systems, where other flexible tubings fail. Fluran® Severe Environment Tubing can be used in continuous service with temperatures as high as 400°F (204°C) and has excellent resistance to corrosive chemicals, oils, fuels, solvents and most mineral acids.

This opaque black tubing helps protect light-sensitive materials being transferred and will not prematurely crack and age when exposed to ozone, sun and weather. It is highly flexible and resilient, making it the ideal choice in peristaltic pumping of extremely corrosive materials. A food grade formulation is available upon request. Durometer hardness: Shore A, 60.*

Tygon® Fluran® Severe Environment Tubing

ORDER #	ID (MM)	OD (MM)	ID (IN)	OD (IN)	length (m)	length (ft)
72-1008	1.6	3.2	1/16	1/8	15.2	50
72-1012	7.9	11.1	5/16	7/16	15.2	50

* Note: Higher durometer values correlate with stiffer less flexible tubing.

Platinum Cured Silicone Tubing

Platinum Cured Silicone



KEY FEATURES

- Excellent for use as catheters, drains and IV drug delivery
- Ultra-pure biocompatible tubing
- Autoclavable
- Resistant to temperature extremes

This Platinum Cured Silicone tubing is ultra-flexible and can be sterilized by autoclaving. It is an ultra-pure biopharmaceutical grade tubing which imparts no tastes or odors to fluids transferred. Resistant to temperature extremes, ozone, radiation, moisture, compression sets, weathering, and chemical attack. Ideal for applications such as sterile fill and transfers, biocompatible for use as catheters, drains and intravenous drug delivery and blood withdrawal. Non-toxic and non-hemolytic.

Platinum Cured Silicone Tubing

ORDER #	ID (MM)	OD (MM)	ID (IN)	OD (IN)	length (m)	length (ft)
72-1045	0.8	1.7	0.030	0.066	7.6	25
72-1046	0.8	4.1	0.030	0.160	7.6	25
72-4189	0.8	2.4	1/32	3/32	15.2	50
72-1050	1.6	3.2	1/16	1/8	7.6	25
72-1049	1.6	4.8	1/16	3/16	7.6	25
72-1056	2.0	3.6	5/64	9/64	7.6	25
72-1062	2.4	4.0	3/32	5/32	7.6	25
72-1061	2.4	5.6	3/32	7/32	7.6	25
72-1066	2.4	7.1	3/32	9/32	7.6	25

* Note: Higher durometer values correlate with stiffer less flexible tubing.

Laboratory Tubing (continued)

Platinum Cured Silicone Tubing (continued)

Platinum Cured Silicone Tubing						
ORDER #	ID (MM)	OD (MM)	ID (IN)	OD (IN)	length (m)	length (ft)
72-1068	3.2	4.8	1/8	3/16	7.6	25
72-1067	3.2	6.4	1/8	1/4	7.6	25
72-1074	4.0	5.6	5/32	7/32	7.6	25
72-1073	4.0	7.1	5/32	9/32	7.6	25
72-1080	4.8	6.4	3/16	1/4	7.6	25
72-1079	4.8	7.9	3/16	5/16	7.6	25
72-1084	4.8	9.5	3/16	3/8	7.6	25
72-1082	4.8	11.1	3/16	7/16	7.6	25
72-1086	6.4	7.9	1/4	5/16	7.6	25
72-1085	6.4	9.5	1/4	3/8	7.6	25
72-1090	6.4	11.1	1/4	7/16	7.6	25
72-1088	6.4	12.7	1/4	1/2	7.6	25
72-1089	6.4	15.9	1/4	5/8	7.6	25
72-1092	7.9	9.5	5/16	3/8	7.6	25
72-1091	7.9	11.1	5/16	7/16	7.6	25

* Note: Higher durometer values correlate with stiffer less flexible tubing.

Platinum Cured Silicone Tubing						
ORDER #	ID (MM)	OD (MM)	ID (IN)	OD (IN)	length (m)	length (ft)
72-1097	9.5	12.7	3/8	1/2	7.6	25
72-1102	9.5	14.3	3/8	9/16	3.0	10
72-1104	12.7	14.3	1/2	9/16	3.0	10

* Note: Higher durometer values correlate with stiffer less flexible tubing.

Laboratory Tubing (continued)

Tygon® Microbore Tubing (ND 100-80)

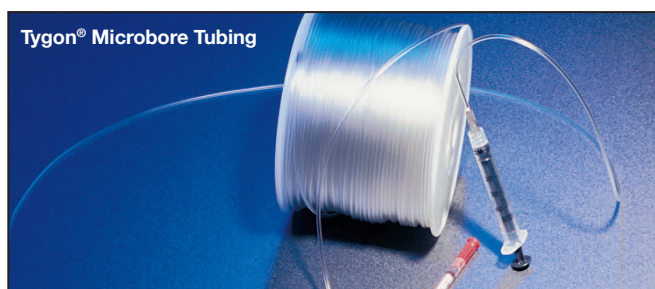

KEY FEATURES

- Stiff enough for easy handling, soft enough to resist puncturing
- Micro-diameter sizes fit needle gauges 30 to 17
- Ideal for precision injection and dispensing applications
- Meets USP Class VI criteria

Tygon® Microbore Tubing is designed for precision injection and dispensing in surgical and laboratory applications.

Select Tygon® Microbore Tubing for intravenous and arterial infusion as well as other surgical and laboratory applications. It is flexible enough to permit the use of a single size tubing with several different needle gauges, yet sufficiently rigid to minimize the danger of wall collapse. Tygon® Microbore Tubing is non-toxic, non-pyrogenic and biocompatible. Tygon® Microbore Tubing can be sterilized by radiation, ethylene oxide, steam or chemical methods. Durometer hardness: Shore A, 80.*

Tygon® Microbore Tubing (ND 100-80)					
ORDER #	ID (mm)	OD (mm)	OD (in.)	length(m)	length(ft.)
75-0465	0.25	0.010	0.030	152.4	500
75-0466	0.51	0.020	0.060	152.4	500
75-0468	1.02	0.040	0.070	152.4	500
75-0469	1.27	0.050	0.090	152.4	500

* Note: Higher durometer values correlate with stiffer less flexible tubing.

Micro-Line™ Tubing

This remarkable new cross-linked Ethyl Vinyl Acetate Tubing is ideal for biological use. It is stable, non-contaminating and contains no plasticizers that could migrate or leach out.

The mechanical properties of this material are unique. It has virtually 100% elastic memory and will return to its original shape after stretching by gentle heating. It will stretch to fit over tubes and fittings. Micro-Line™ Tubing can be shaped with heat to form various shapes or can be cold-stretched to reduce the internal diameter by 40%. Tubing is flexible and non-kinking from below zero to 180°F.

Micro-Line™ Tubing						
ORDER #	ID (mm)	OD (mm)	ID (in.)	OD (in.)	length(m)	length(ft.)
59-8644	1.0	1.8	0.040	0.070	30.5	100
59-8645	1.3	2.3	0.050	0.090	30.5	100

Disposable Pressure Tubing

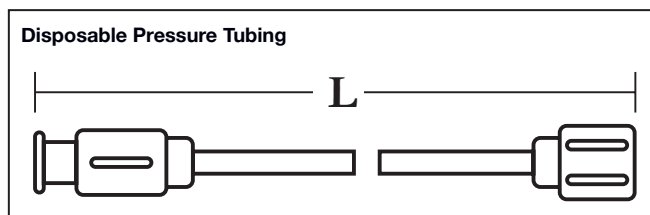

KEY FEATURES

- Ideal for infusion studies
- Easily extend infusion lines from syringe to needle or catheter

This Pressure Tubing is the ideal way to connect the output from a syringe to the delivery mechanism for an infusion study. It has a male Luer Lock connector on one end and a female Luer Lock connector on the other. This tubing has an ID of 1.6 mm (1/16 in) and an OD of 3.2 mm (1/8 in). Tubing volume is 0.6 ml per 12 inches of tubing. It is available in 8 lengths and is supplied sterile in packages of 25.

Disposable Pressure Tubing	
Order #	Product
63-0281	Disposable Pressure Tubing, 15.2 cm (6 in)
63-0282	Disposable Pressure Tubing, 30.5 cm (12 in)
63-0283	Disposable Pressure Tubing, 61 cm (24 in)
63-0284	Disposable Pressure Tubing, 91.4 cm (36 in)
63-0287	Disposable Pressure Tubing, 182.9 cm (72 in)
63-0288	Disposable Pressure Tubing, 213.4 cm (84 in)

Disposable High Pressure Tubing

This Tubing is similar to the tubing described above except it can withstand pressures up to 1000 p.s.i. It has a male Luer Lock connector on one end and a female on the other. This tubing has an ID of 1.6 mm (1/16 in) and an OD of 3.2 mm (1/8 in). Supplied as straight pieces of tubing in a package of 10.

PolyE Polyethylene Tubing

Harvard Apparatus' PolyE polyethylene tubing is an excellent tubing choice for a variety of applications requiring small ID or OD tubing. It is available in both sterile and non-sterile packages. It can be used for infusions, tracheotomies or other surgical operations in rodents from mice to rabbits. Cross reference numbers to PE tubing is provided. Blunt probe needles can be used with this tubing to make custom cannulae. Information in the table will assist in needle selection. One column lists the size of needle which will fit into the tubing while the other column lists the size of needle through which each tubing size will pass.

Sterile PolyE Polyethylene Tubing				
NEEDLE GAUGE				
ORDER #	PE No.	Diameter ID x OD	Needle In Tubing	Tubing In Needle
Length 30.5 cm (12 in)				
59-8357	50	0.58 x 0.965 mm (0.023 x 0.038 in)	23 g	17 g
Length 91.45 cm (36 in)				
59-8358	50	0.58 x 0.965 mm (0.023 x 0.038 in)	23 g	17 g
59-8360	90	0.86 x 1.27 mm (0.034 x 0.050 in)	20 g	15 g
59-8364	190	1.19 x 1.70 mm (0.047 x 0.067 in)	18 g	13 g

PolyE Tubing Size Cross Reference Chart

Use this chart below to determine comparable sizes of PolyE and French scale tubing

French* Number	PolyE Number	OD (in)	French* Number	PolyE Number	OD (in)
1	-	0.013	6.2	420	0.082
1.8	100	0.024	7	-	0.092
2	-	0.026	7.2	460	0.095
2.4	140	0.031	8	-	0.105
2.9	200	0.038	8.1	380	0.106
3	160	0.039	9.0	500	0.118
3.2	120	0.043	9.8	520	0.128
3.8	260	0.050	10	-	0.131
4	-	0.052	11	540	0.145
4.6	280	0.060	11.6	605	0.153
4.7	320	0.062	12.3	580	0.161
5	-	0.066	13	-	0.171
5.1	340	0.067	14	-	0.184
5.9	300	0.078	15	-	0.197
6	-	0.079	16	-	0.210
			17	-	0.223
			17.9	680	0.236

* French Scale = OD (in) x 76.211 - 0.0014

Non-Sterile PolyE Polyethylene Tubing							
Tubing Length 3m (10 ft)	30.5 m (100 ft)	PE No.	Diameter ID x OD mm (in)	Needle Gauge French Scale*	Needle Gauge Needle into Tubing	PE # Tubing into Needle	PolyE Equiv.
72-0191	72-0192	-	0.40 x 0.80 (0.016 x 0.031)	2.4	26 g	18 g	140
59-8329	-	90	0.86 x 1.27 (0.034 x 0.050)	3.8	20 g	15 g	260
72-0195	72-0196	-	1.02 x 1.98 (0.04 x 0.078)	5.9	18 g	12 g	300
59-8341	59-8342	240	1.67 x 2.42 (0.066 x 0.095)	7.2	14 g	10 g	460
59-8343	59-8344	260	2.0 x 3.0 (0.079 x 0.118)	9.0	14 g	8 g	500
59-8351	59-8352	350	3.0 x 3.88 (0.118 x 0.153)	11.6	10 g	6 g	605
59-8355	59-8356	380	4.0 x 6.0 (0.157 x 0.236)	17.9	9 g	NA	680
64-0750		10	0.28 x 0.61 mm (ID x OD)				
64-0752		50	0.58 x 0.96 mm (ID x OD)	2.9	23 g	17 g	200
64-0754		90	0.86 x 1.27 mm (ID x OD)	3.8	20 g	15 g	260
64-0755		160	1.14 x 1.57 mm (ID x OD)				

* French Scale = OD (in) x 76.211 - 0.0014

Barbed Tubing Connectors

Tubing Connector Kits & Stopcocks

Harvard Apparatus offers a complete line of tubing connector kits to assist you in quickly and easily making connections between syringes and tubing and between tubing of similar and dissimilar sizes. Kit types include: barbed connector kits (small, medium and large), Kent® Systems Quick Disconnect Kits, Luer connector kits, a stopcock kit, a tubing clamp kit, fitting and tubing kit and a tubing manifold kit. Some kits are available in multiple material types where chemical compatibility may be a concern. Each kit is supplied in a convenient storage box and kit component are also sold separately.

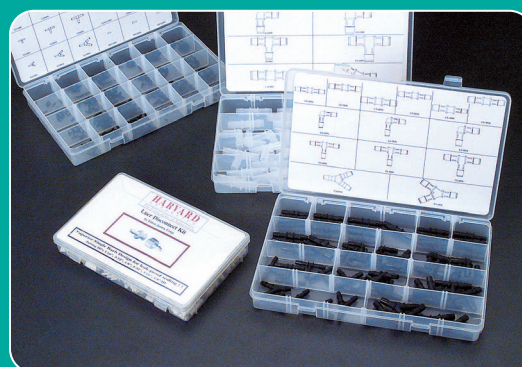

Kent® Systems Quick Disconnect Kits



These kits feature the Kent® Systems quick disconnect (KSQD) fittings. Fittings are available as either male or female KSQD. Fitting styles include integral male or female, swivel male (with or without lock), locking male fitting, male to female KSQD shut-off valve, male plug, male/female plug, male flush plug, female cap, male flush plug and the modular manifold. The modular manifold has three female and one male KSQD fittings. Modular manifolds can be interconnected with any fitting including other modular manifolds to quickly and easily interconnect a number of tubes of similar or dissimilar sizes. The unique barbs are sized to accommodate a range of tube sizes and tube types. Each kit is supplied in a convenient box.

Kent® Systems Quick Disconnect Kits Barb Size Chart

Barb No.	Barb OD	Barb Bore		Tube ID Range
		Lower	Upper	
004	0.102 in	0.06 in	0.063 in	0.078 in
007	0.129 in	0.076 in	0.078 in	0.109 in
013	0.164 in	0.096 in	0.094 in	0.141 in
025	0.208 in	0.122 in	0.125 in	0.188 in
035	0.264 in	0.155 in	0.156 in	0.234 in
055	0.335 in	0.197 in	0.188 in	0.297 in

Order #	Barb Size	Kit Size	Tube ID Range
72-1613	004, 007, 013	Small	1/16, 3/32 and 1/8 in
72-1614	025, 035, 055	Large	5/32, 3/16 and 1/4 in

Barbed Tubing Connectors (continued)

Barbed Connector Kits



These barbed connector kits come in three different sizes. Small and medium kits have 10 pieces of each component and large kits have 5 pieces of each component. These kits are available in polypropylene, and Kynar®, a chemically resistant autoclavable plastic. Each kit is supplied in a convenient box.

Barbed Tubing Connector Kits

PRODUCT	TUBE ID	MATERIAL
72-1410 Small Polypropylene Barbed Connector Kit		
KIT COMPONENTS:		
Barbed Connector	1/16 to 1/16 in	Polypropylene
Barbed Connector	3/32 to 3/32 in	Polypropylene
Barbed Connector	1/8 to 1/8 in	Polypropylene
Barbed Connector	1/16 to 3/32 in	Polypropylene
Barbed Connector	1/16 to 1/8 in	Polypropylene
Barbed Connector	3/32 to 1/8 in	Polypropylene
L Barbed Connector	1/16 to 1/16 in	Polypropylene
L Barbed Connector	3/32 to 3/32 in	Polypropylene
L Barbed Connector	1/8 to 1/8 in	Polypropylene
L Barbed Connector	1/16 to 3/32 in	Polypropylene
L Barbed Connector	1/16 to 1/8 in	Polypropylene
L Barbed Connector	3/32 to 1/8 in	Polypropylene
T Barbed Connector	1/16 to 1/16 in	Polypropylene
T Barbed Connector	3/32 to 3/32 in	Polypropylene
T Barbed Connector	1/8 to 1/8 in	Polypropylene
T Barbed Connector	1/16 to 3/32 in	Polypropylene
T Barbed Connector	1/16 to 1/8 in	Polypropylene
T Barbed Connector	3/32 to 1/8 in	Polypropylene
Y Barbed Connector	1/16 to 1/16 in	Polypropylene
Y Barbed Connector	3/32 to 3/32 in	Polypropylene
Y Barbed Connector	1/8 to 1/8 in	Polypropylene
Barbed PLUG Connector	1/16 in	Polypropylene
Barbed PLUG Connector	3/32 in	Polypropylene
Barbed PLUG Connector	1/8 in	Polypropylene

Barbed Tubing Connector Kits (Continued)

PRODUCT	TUBE ID	MATERIAL
72-1411 Small Kynar® Barbed Connector Kit		
KIT COMPONENTS:		
Barbed Connector	1/16 to 1/16 in	Kynar®
Barbed Connector	3/32 to 3/32 in	Kynar®
Barbed Connector	1/8 to 1/8 in	Kynar®
Barbed Connector	1/16 to 3/32 in	Kynar®
Barbed Connector	1/16 to 1/8 in	Kynar®
Barbed Connector	3/32 to 1/8 in	Kynar®
L Barbed Connector	3/32 to 3/32 in	Kynar®
L Barbed Connector	1/8 to 1/8 in	Kynar®
L Barbed Connector	1/16 to 1/8 in	Kynar®
T Barbed Connector	1/16 to 1/16 in	Kynar®
T Barbed Connector	3/32 to 3/32 in	Kynar®
T Barbed Connector	1/8 to 1/8 in	Kynar®
T Barbed Connector	1/16 to 1/8 in	Kynar®
T Barbed Connector	3/32 to 1/8 in	Kynar®
Y Barbed Connector	1/16 to 1/16 in	Kynar®
Y Barbed Connector	3/32 to 3/32 in	Kynar®
Y Barbed Connector	1/8 to 1/8 in	Kynar®

Barbed Tubing Connectors (continued)

Barbed Tubing Connector Kits (Continued)

PRODUCT	TUBE ID	MATERIAL
72-1413 Medium Polypropylene Barbed Connector Kit		
KIT COMPONENTS:		
Barbed Connector	1/4 to 1/4 in	Polypropylene
Barbed Connector	5/16 to 5/16 in	Polypropylene
Barbed Connector	3/8 to 3/8 in	Polypropylene
Barbed Connector	1/4 to 5/16 in	Polypropylene
Barbed Connector	1/4 to 3/8 in	Polypropylene
Barbed Connector	5/16 to 3/8 in	Polypropylene
L Barbed Connector	1/4 to 1/4 in	Polypropylene
L Barbed Connector	5/16 to 5/16 in	Polypropylene
L Barbed Connector	3/8 to 3/8 in	Polypropylene
T Barbed Connector	1/4 to 1/4 in	Polypropylene
T Barbed Connector	5/16 to 5/16 in	Polypropylene
T Barbed Connector	3/8 to 3/8 in	Polypropylene
Y Barbed Connector	1/4 to 1/4 in	Polypropylene
Y Barbed Connector	3/8 to 3/8 in	Polypropylene

72-1414 Medium Kynar® Barbed Connector Kit

PRODUCT	TUBE ID	MATERIAL
KIT COMPONENTS:		
Barbed Connector	1/4 to 1/4 in	Kynar®
Barbed Connector	5/16 to 5/16 in	Kynar®
Barbed Connector	3/8 to 3/8 in	Kynar®
Barbed Connector	1/4 to 5/16 in	Kynar®
Barbed Connector	1/4 to 3/8 in	Kynar®
Barbed Connector	5/16 to 3/8 in	Kynar®
L Barbed Connector	1/4 to 1/4 in	Kynar®
L Barbed Connector	5/16 to 5/16 in	Kynar®
L Barbed Connector	3/8 to 3/8 in	Kynar®
T Barbed Connector	1/4 to 1/4 in	Kynar®
T Barbed Connector	5/16 to 5/16 in	Kynar®
T Barbed Connector	3/8 to 3/8 in	Kynar®
Y Barbed Connector	1/4 to 1/4 in	Kynar®
Y Barbed Connector	3/8 to 3/8 in	Kynar®



PRODUCT	TUBE ID	MATERIAL
72-1416 Large Polypropylene Barbed Connector Kit		

KIT COMPONENTS:

Barbed Connector	1/2 to 1/2 in	Polypropylene
Barbed Connector	5/8 to 5/8 in	Polypropylene
L Barbed Connector	1/2 to 1/2 in	Polypropylene
L Barbed Connector	5/8 to 5/8 in	Polypropylene
T Barbed Connector	1/2 to 1/2 in	Polypropylene
T Barbed Connector	5/8 to 5/8 in	Polypropylene
Y Barbed Connector	1/2 to 5/8 in	Polypropylene
Y Barbed Connector	1/2 to 1/2 in	Polypropylene

PC6 72-1417 Large Kynar® Barbed Connector Kit

KIT COMPONENTS:

Barbed Connector	1/2 to 1/2 in	Kynar®
Barbed Connector	5/8 to 5/8 in	Kynar®
L Barbed Connector	1/2 to 1/2 in	Kynar®
L Barbed Connector	5/8 to 5/8 in	Kynar®
T Barbed Connector	1/2 to 1/2 in	Kynar®
T Barbed Connector	5/8 to 5/8 in	Kynar®
Y Barbed Connector	1/2 to 5/8 in	Kynar®
Y Barbed Connector	1/2 to 1/2 in	Kynar®

Barbed Tubing Connectors (continued)

Luer to Tube Kits



The Luer Connector Kits contain a selection of Luer fittings to interconnect Luer connectors (e.g. syringes, stopcocks and needles) with one another and with tubing. These kits are available in polypropylene and Kynar®, a chemically resistant autoclavable plastic. Each kit is supplied in a convenient box.

The Male Luer Taper kits contain a selection of Male Luer Taper fittings to barbed connectors as well as Male Luer Taper to Male Luer Taper fittings. These kits also contain color coded rotating Luer lock rings that securely snap onto the Male Luer Taper side of each connector. These kits are available in polypropylene and Kynar®, a chemically resistant autoclavable plastic. Each kit is supplied in a convenient box.

Luer to Tube Kits

PRODUCT	TUBE ID	MATERIAL
72-1407 Polypropylene Luer Connector Kit		
KIT COMPONENTS:		
Barbed Connector	FLL to 1/16	Polypropylene
Barbed Connector	FLL to 3/32	Polypropylene
Barbed Connector	FLL to 1/8	Polypropylene
Barbed Connector	FLL to 5/32	Polypropylene
Barbed Connector	FLL to 3/16	Polypropylene
Barbed Connector	FLL to 1/4	Polypropylene
Barbed Connector	MLL to 1/16	Polypropylene
Barbed Connector	MLL to 3/32	Polypropylene
Barbed Connector	MLL to 1/8	Polypropylene
Barbed Connector	MLL to 5/32	Polypropylene
Barbed Connector	MLL to 3/16	Polypropylene
Barbed Connector	MLL to 1/4	Polypropylene
Cap Connector	MLL	Polypropylene
Cap Connector	FLL	Polypropylene
Coupler w/ Threaded FLL Connection	FLL to MLL	Polypropylene
Connector	MLT to MLT	Polypropylene
Connector	FLL to FLL	Polypropylene
Elbow Connector	FLL to FLL	Polypropylene
T Connector	3-Way FLL	Polypropylene

72-1408 Kynar® Luer Connector Kit

KIT COMPONENTS:		
Barbed Connector	FLL to 1/16	Kynar®
Barbed Connector	FLL to 3/32	Kynar®
Barbed Connector	FLL to 1/8	Kynar®
Barbed Connector	MLL to 1/16	Kynar®
Barbed Connector	MLL to 1/8	Kynar®
Barbed Connector	MLL to 5/32	Kynar®
Barbed Connector	MLL to 3/16	Kynar®
Barbed Connector	MLL to 1/4	Kynar®
Cap Connector	MLL	Kynar®
Cap Connector	FLL	Kynar®
Coupler w/Threaded FLL Connection	FLL to MLL	Kynar®
Connector	MLT to MLT	Kynar®
Connector	FLL to FLL	Kynar®

Barbed Tubing Connectors (continued)

Luer to Tube Kits (Continued)		
PRODUCT	TUBE ID	MATERIAL
72-2739 Polypropylene Male Luer Taper Kit		
KIT COMPONENTS:		
Snap Luer Lock Ring	Male	Red Nylon
Snap Luer Lock Ring	Male	Green Nylon
Snap Luer Lock Ring	Male	Polypropylene
Barbed Connector	MLT to 1/16 in (R)*	Polypropylene
Barbed Connector	MLT to 3/32 in (R)*	Polypropylene
Luer Coupler	Male	Polypropylene
Barbed Connector	MLT to 1/8 in (R)*	Polypropylene
Barbed Connector	MLT to 5/32 in (R)*	Polypropylene
Barbed Connector	MLT to 3/16 in (R)*	Polypropylene
Barbed Connector	MLT to 1/4 in (R)*	Polypropylene
Barbed Connector	MLT to 1/16 in (S)*	Polypropylene
T Connector	FLL/MLT/MLT	Polypropylene
Barbed Connector	MLT to 3/32 in (S)*	Polypropylene
Barbed Connector	MLT to 1/8 in (S)*	Polypropylene
Barbed Connector	MLT to 5/32 in (S)*	Polypropylene
Barbed Connector	MLT to 3/16 in (S)*	Polypropylene
Barbed Connector	MLT to 1/4 in (S)*	Polypropylene
T Connector	FLL/MLT/FLL	Polypropylene

* (R) Allows rotation of tube on measured end.

(S) Does not allow rotation on measured end

Tubing Clamp Kits



The clamps in the Tubing Clamp Kit feature a simple-to-use ratcheting design which provides positive and secure clamping of tubing to barbed and non-barbed connectors. Thirteen different clamps provide clamping for tubing sizes from 1/16 inch OD to 1.5 inches OD. This kit is supplied in a convenient box containing 5 of each clamp size.

Order #	Product
72-1668	Tubing Clamp Kit

Luer to Tube Kits (Continued)		
PRODUCT	TUBE ID	MATERIAL
72-2740 Polycarbonate Male Luer Taper Kit		
KIT COMPONENTS:		
Snap Luer Lock Ring	Male	Red Nylon
Snap Luer Lock Ring	Male	Green Nylon
Snap Luer Lock Ring	Male	Polycarbonate
Barbed Connector	MLT to 1/16 in (R)*	Polycarbonate
Barbed Connector	MLT to 3/32 in (R)*	Polycarbonate
Luer Coupler	Male	Polycarbonate
Barbed Connector	MLT to 1/8 in (R)*	Polycarbonate
Barbed Connector	MLT to 5/32 in (R)*	Polycarbonate
Barbed Connector	MLT to 3/16 in (R)*	Polycarbonate
Barbed Connector	MLT to 1/4 in (R)*	Polycarbonate
Barbed Connector	MLT to 1/16 in (S)*	Polycarbonate
T Connector	FLL/MLT/MLT	Polycarbonate
Barbed Connector	MLT to 3/32 in (S)*	Polycarbonate
Barbed Connector	MLT to 1/8 in (S)*	Polycarbonate
Barbed Connector	MLT to 5/32 in (S)*	Polycarbonate
Barbed Connector	MLT to 3/16 in (S)*	Polycarbonate
Barbed Connector	MLT to 1/4 in (S)*	Polycarbonate
T Connector	FLL/MLT/FLL	Polycarbonate

Flow Control Pinch Valves



The Flow Control Pinch Valves work with tubing from 5/32 inch OD to 3/8 inch OD. The micrometer dial offers easy resetting of clamping distance. These valves are made of Delrin® and Acetal.

Order #	Clamp Size	Tubing Clamp Range
72-2694	Small	5/32 to 1/4 in OD Tubing
72-8140	Medium	5/32 to 3/8 in OD Tubing

Kits and Valves

Tubing Manifold Kit



The Tubing Manifold Kit contains several varieties of tubing manifolds for tube to tube connections. Many are compatible with MLT (male Luer taper) fittings. This kit is supplied in a convenient box. All kit components are also sold separately.

Tubing Manifold Kit

ORDER #	PRODUCT
72-7481	Tubing Manifold Kit

KIT COMPONENTS:

72-2673	Y Connector FLL/FLL/MLL (Rotating)
---------	------------------------------------

Luer Stopcock Kit

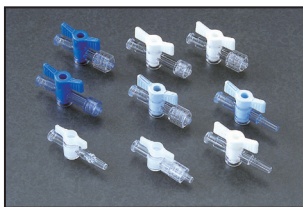

The Luer Stopcock Kit includes a collection of 1-, 3- and 4-way stopcocks. Fittings include MLL (male Luer lock), FLL (female Luer lock) and Male Luer Slip. Some stopcocks have high pressure capabilities. This kit is supplied in a convenient box. All kit components are also sold separately.

Luer Stopcock Kit

ORDER #	PRODUCT
72-1664	Luer Stopcock Kit

KIT COMPONENTS:

72-8327	One Way Stopcock (200 psi), FLL/Male Luer Slip
72-2648	3-Way Stopcock (1050 psi), FLL/FLL/MLL (Rotating)
72-2650	One Way Stopcock (1050 psi), FLL/MLL (Non-Rotating)
72-8326	One Way Stopcock (200 psi), FLL/MLL (Rotating)
72-2693	3-Way Stopcock (200 psi), FLL/FLL/Male Luer Slip
72-2655	One Way Stopcock (1050 psi), FLL/MLL (Rotating)
72-2657	One Way Stopcock (500 psi), FLL/MLL (Rotating)
72-2658	3-Way Stopcock (1050 psi), FLL/FLL/MLL (Non-Rotating)
72-2659	3-Way Stopcock, FLL/FLL/FLL
72-2660	3-Way Stopcock (500 psi), FLL/FLL/MLL (Non-Rotating)
72-2662	3-Way Stopcock (200 psi), FLL/FLL/MLL (Rotating)
72-9473	3-Way Stopcock (130 psi), FLL/FLL/MLL (Non-Rotating)

Micro Tubing and Connector Kit, Syringe Needles

Parts and Accessories



The kit is comprised of barbed and Luer fittings, blunt end needles, and an assortment of PE and C-Flex tubing. All barbed and Luer fittings are made from polypropylene and include tube to tube, reducing, Y-, T-, Luer-to-Luer, and Luer-to-barb adapters. Comes in a convenient plastic storage box.

Product

64-1565 KIT-1 Fitting and Tubing Kit

KIT COMPONENTS:

Tube Fitting Barb 1/8" to 1/16", pkg. of 10
Tube Fitting Barb 1/16" to 1/16", pkg. of 10
Tube Fitting Barb 1/8" to 1/8", pkg. of 10
Tube Fitting Tee Barb 1/16", pkg. of 10
Tube Fitting Tee Barb 1/8", pkg. of 10
Tube Fitting Y Barb 1/16", pkg. of 10
Tube Fitting Y Barb 1/8", pkg. of 10
Tube Fitting Barb 1/16" to Luer Male, pkg. of 10
Tube Fitting Barb 1/8" to Luer Male, pkg. of 10
Tube Fitting Barb 1/16" to Luer Female, pkg. of 10
Tube Fitting Barb 1/8" to Luer Female, pkg. of 10
Tube Fitting Luer Male to Luer Female, pkg. of 10
Tube Fitting Luer Tee Female, pkg. of 10
Tube Fitting Luer Male to Luer Male, pkg. of 10
Tube Fitting Luer Female to Luer Female, pkg. of 10
Tube Fitting Luer Female Plug, pkg. of 10
Tube Fitting Luer Male Plug, pkg. of 10
LPE-50, Luer to PE-50 tubing adapter, pkg. of 8
CFL-6, C-Flex tubing (1/32" ID x 6 ft) 3/32 OD mm, 6 ft

BLUNT NEEDLE PLASTIC HUB

SN-18, 18G, 0.5", pkg. of 12
SN-23, 23G, 0.5", pkg. of 12
SN-30, 30G, 0.5", pkg. of 12
SN-20, 20G, 0.5", Pkg. of 12

POLYETHYLENE TUBING

PE-10/10., 0.28 ID x 0.61 OD mm, 3.1 m (10 ft) long
PE-50/10., 0.58 ID x 0.97 OD mm, 3.1 (10 ft) long
PE-90/10., 0.86 ID x 1.27 OD mm, 3.1 m (10 ft) long
PE-160/10., 1.14 ID x 1.57 OD mm, 3.1 m (10 ft) long

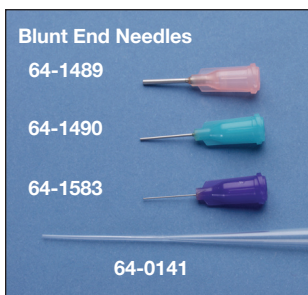
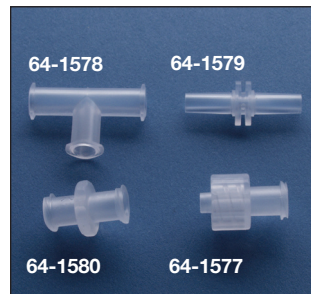
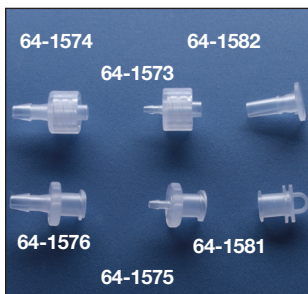
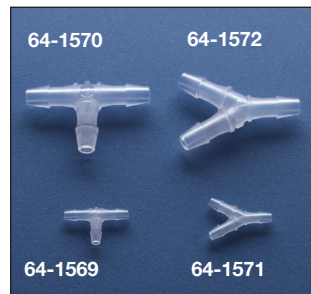

ML, MM, MP and MPP Series Manifolds and Flow Control Hardware

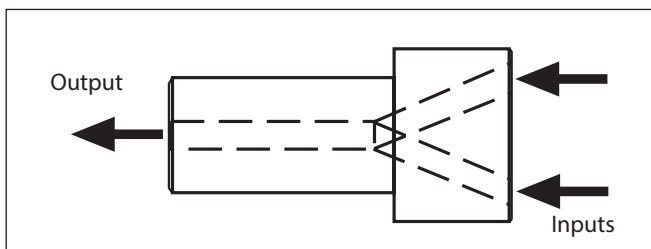
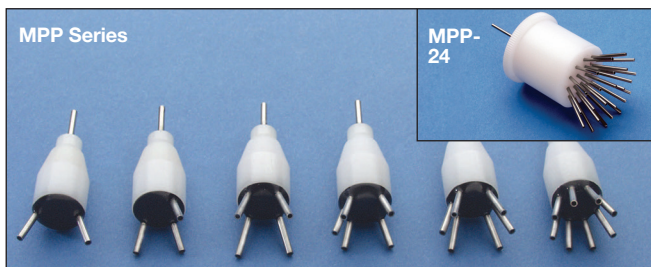
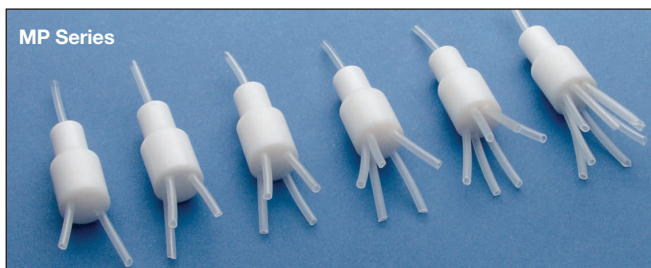
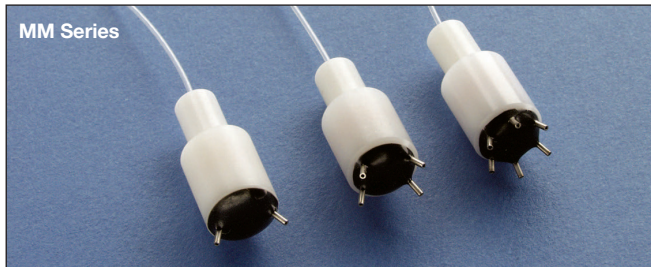
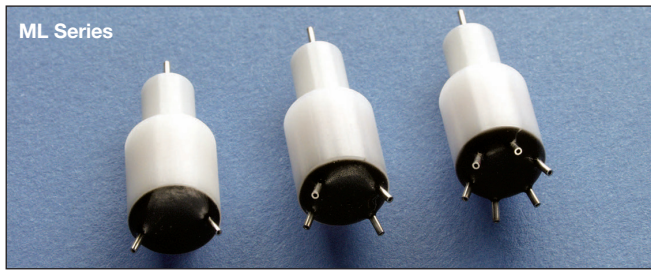

ML, MM, MP and MPP Series Material and Size Chart

	ML Series	MM Series	MP Series	MPP Series
MATERIAL	Delrin™	Delrin™	PTFE	Delrin™
LARGE DIAMETER	8.0 mm	8.0 mm	9.4 mm	9.4 mm
SMALL DIAMETER	4.7 mm	4.7 mm	6.3 mm	4.7 mm
BODY LENGTH	18 mm	18 mm	22 mm	21 mm
INPUT TUBING	PE-50	PE-50	PE-160	PE-160

Multi-in or multi-out manifolds for fluid management

Harvard Apparatus manifolds can be used in any application where from 2 to 8 perfusion lines are required to be connected to a chamber or other device. Manifold inputs converge to the common output with minimum dead space. Designed for use with polyethylene (PE) tubing, manifolds can be used with any other tubing of similar dimensions. When connected to a chamber via a short length of tubing, very rapid solution changes are possible.

ML and MM Series

These miniature manifolds are useful for applications involving small volumes or slow flow rates. Small diameter tubing is used with these models; PE-50 tubing for the input ports, and PE-10 or PE-50 tubing for the MM or ML series output ports, respectively.

MP Series

MP series manifolds are recommended low pressure (< 25 psi) systems. Input and output tubing are inserted with a friction fit. Manifolds should be ordered with inputs to match the number of solutions to be connected. Pin plugs to block unused inputs are also supplied. MP series manifolds are used with PE-160 tubing.

MPP Series

These manifolds are suitable for systems in which solutions are pumped or at pressures < 25 psi. Input and output ports are 18 gauge stainless steel hypodermic tubing. PE-160 tubing slides over these ports to make a snug fit.

Order #	Model	Product
64-0200	ML-2	Miniature Manifold, 2 ports
64-0201	ML-4	Miniature Manifold, 4 ports
64-0202	ML-6	Miniature Manifold, 6 ports
64-0199	ML-8	Miniature Manifold, 8 ports
64-0203	MM-2	Miniature Manifold, 2 ports
64-0204	MM-4	Miniature Manifold, 4 ports
64-0205	MM-6	Miniature Manifold, 6 ports
64-0206	MP-2	MP Manifold, 2 ports
64-0207	MP-3	MP Manifold, 3 ports
64-0208	MP-4	MP Manifold, 4 ports
64-0209	MP-5	MP Manifold, 5 ports
64-0210	MP-6	MP Manifold, 6 ports
64-0211	MP-8	MP Manifold, 8 ports
64-0212	MPP-2	MPP Manifold, 2 ports
64-0213	MPP-3	MPP Manifold, 3 ports
64-0214	MPP-4	MPP Manifold, 4 ports
64-0215	MPP-5	MPP Manifold, 5 ports
64-0216	MPP-6	MPP Manifold, 6 ports
64-0217	MPP-8	MPP Manifold, 8 ports
64-0339	MPP-24	MPP Manifold, 24 ports

All manifolds can be easily disassembled for cleaning.

How to Calculate the Pressure Requirement of Your Experiment

The following chart will help you determine the pressure requirement of your experiment. This is important in selecting the correct pump with the proper psi capability for your application. Choose the selections that are the closest to your experimental conditions or write in your actual values. Once you have filled in the chart call us for technical assistance if needed.

- Nature of the sample you are flowing into (Application)
- The flow rate of the material
- The surface area of the syringe and the linear force capability of the pump
- The tubing diameter
- The tubing length

		NORMAL PRESSURE 0 to 30 psi (0 to 2 bar)	HIGH FORCE 31 to 150 psi (2.1 to 10.2 bar)	EXTREME HIGH PRESSURE 151 to 2000 psi (10.3 to 137 bar)
1. Application				
L	Flow into open containers, i.e. titrations, food trays filling			
O	Inject into Tissue, i.e. Drug infusion into muscle, brain			
H	Flow into closed container, i.e. Reaction Chamber 350 to 400 psi			
G	High viscosity solutions at high flow rates in a short period of time, i.e. Corn syrup			
2. FLOW RATE -Pumping Speed (The faster the flow rate, the higher the pressure)				
	0.003 µl/hr to 140 ml/min			
	141 ml/min to 220 ml/min			
3. SYRINGE SIZE (Syringe volume/plunger area + linear force of pump)				
	10 µl to 1 ml ie. 500 µl/min x 20 lb = 1500 psi			
4. TUBING SIZE (Inner diameter, Smaller ID = higher pressure)				
	SMALL -Capillary (the longer more pressure)			
	LARGE -Hose			
5. TUBING LENGTH -DISTANCE (Depends on ID Smaller ID = higher pressure)				
	Short, < 1M			
	Long, > 1M			
6. VISCOSITY OF MATERIAL TO BE PUMPED (Higher viscosity = higher pressure)				
	AIR 18°C = 0.0182 cP			
	WATER 20°C = 1.002 cP			
	OLIVE OIL 20°C = 84 cP			
	PANCAKE SYRUP 20°C = 2500 cP			
	HONEY 20°C = 10000 cP			
	PEANUT BUTTER 20°C = 250000 cP			
7. TEMPERATURE OF SOLUTIONS BEING PUMPED (Higher temperature = lower viscosity = lower pressure)				
	0 to 15°C			
	15 to 80°C			

Syringe Pump Pressure and Flow Rate

How to Calculate the Pressure of Various Syringe Sizes

The pressure that a syringe pump can generate is a function of both the force of the pump (measured at the pusher block in pounds) as well as the physical characteristics of the syringe and setup used. The following table compares various syringe pumps and the pressures in PSI (pounds per square inch). Each data point was calculated by dividing the average pump force by the surface area (in square inches) of syringes with diameters from 0.1 to 50 mm. Diameters and surface areas for a variety of syringes can be found in the table on page 112. This table is intended to be a guide of total pressures generated. Actual values may be higher or lower than the listed pressures due to the influence of other factors such as tubing diameter and length. When using more than one syringe sharing the same pusher block, the pressure is calculated by dividing the force (lb) by the total surface area (square inches) of all syringes on the pump. For example, nominal pressure obtained using two 25 ml Hamilton Gastight® syringes on a PHD 22/2000 standard pressure syringe pump would be:

Minimum/Maximum Flow Rates by Pump and Syringe Size

Flow rates were calculated based on the pusher block travel rate for each pump (rate at which the syringe pump moves the syringe plunger) and the diameter of the syringe.

Pump 11 Elite Flow Rates

Nominal Minimum/Maximum Flow Rates for Various Syringes.
(Actual Limits will vary depending on syringe manufacturer)

Syringe Size	Diameter *	Minimum	Maximum
0.5 µl	0.103 mm	1.26 pl/min	1.326 µl/min
1 µl	0.146 mm	2.52 pl/min	2.654 µl/min
2 µl	0.206 mm	5.10 pl/min	5.304 µl/min
5 µl	0.343 mm	14.160 pl/min	14.710 µl/min
10 µl	0.485 mm	28.260 pl/min	29.400 µl/min
25 µl	0.729 mm	63.960 pl/min	66.430 µl/min
50 µl	1.030 mm	127.700 pl/min	132.600 µl/min
100 µl	1.457 mm	255.500 pl/min	265.400 µl/min
250 µl	2.304 mm	638.900 pl/min	663.500 µl/min
500 µl	3.256 mm	1.276 nl/min	1.325 ml/min
1000 µl	4.608 mm	2.556 nl/min	2.654 ml/min
1 ml	4.699 mm	2.658 nl/min	2.760 ml/min
3 ml	8.585 mm	8.871 nl/min	9.213 ml/min
5 ml	11.99 mm	17.300 nl/min	17.970 ml/min
10 ml	14.43 mm	25.050 nl/min	26.020 ml/min
20 ml	19.05 mm	43.680 nl/min	45.360 ml/min
30 ml	21.59 mm	56.110 nl/min	58.270 ml/min
50 ml	26.59 mm	85.130 nl/min	88.400 ml/min
60 ml	26.59 mm	85.130 nl/min	88.400 ml/min

* Note: These figures have been rounded and therefore may not exactly match the Syringe Diameter Chart on page 112.

Syringe Pump Pressure and Flow Rate

Minimum/Maximum Flow Rates By Pump and Syringe Size

Pico Plus Elite Flow Rates

Nominal Minimum/Maximum Flow Rates for Various Syringes.
(Actual Limits will vary depending on syringe manufacturer)

Syringe Size	Diameter *	Minimum	Maximum
0.5 µl	0.103 mm	0.54 pl/min	596.5 nl/min
1 µl	0.1457 mm	1.14 pl/min	1.194 µl/min
2 µl	0.206 mm	2.28 pl/min	2.386 µl/min
5 µl	0.343 mm	6.36 pl/min	6.615 µl/min
10 µl	0.485 mm	12.72 pl/min	13.230 µl/min
25 µl	0.729 mm	28.74 pl/min	29.880 µl/min
50 µl	1.030 mm	57.42 pl/min	59.650 µl/min
100 µl	1.457 mm	114.9 pl/min	119.4 µl/min
250 µl	2.304 mm	287.4 pl/min	298.5 µl/min
500 µl	3.256 mm	574.0 pl/min	596.1 µl/min
1000 µl	4.608 mm	1.150 nl/min	1.194 ml/min
1 ml	4.699 mm	1.196 nl/min	1.241 ml/min
3 ml	8.585 mm	3.990 nl/min	4.144 ml/min
5 ml	11.989 mm	7.782 nl/min	8.082 ml/min
10 ml	14.430 mm	11.270 nl/min	11.700 ml/min

* Note: These figures have been rounded and therefore may not exactly match the Syringe Diameter Chart on page 112.

Pump 11 Elite Flow Rates

Nominal Minimum/Maximum Flow Rates for Various Syringes.
(Actual Limits will vary depending on syringe manufacturer)

Syringe Size	Diameter *	Minimum	Maximum
0.5 µl	0.103 mm	1.26 pl/min	1.326 µl/min
1 µl	0.146 mm	2.52 pl/min	2.654 µl/min
2 µl	0.206 mm	5.10 pl/min	5.304 µl/min
5 µl	0.343 mm	14.160 pl/min	14.710 µl/min
10 µl	0.485 mm	28.260 pl/min	29.400 µl/min
25 µl	0.729 mm	63.960 pl/min	66.430 µl/min
50 µl	1.030 mm	127.700 pl/min	132.600 µl/min
100 µl	1.457 mm	255.500 pl/min	265.400 µl/min
250 µl	2.304 mm	638.900 pl/min	663.500 µl/min
500 µl	3.256 mm	1.276 nl/min	1.325 ml/min
1000 µl	4.608 mm	2.556 nl/min	2.654 ml/min
1 ml	4.699 mm	2.658 nl/min	2.760 ml/min
3 ml	8.585 mm	8.871 nl/min	9.213 ml/min
5 ml	11.99 mm	17.300 nl/min	17.970 ml/min
10 ml	14.43 mm	25.050 nl/min	26.020 ml/min
20 ml	19.05 mm	43.680 nl/min	45.360 ml/min
30 ml	21.59 mm	56.110 nl/min	58.270 ml/min
50 ml	26.59 mm	85.130 nl/min	88.400 ml/min
60 ml	26.59 mm	85.130 nl/min	88.400 ml/min

* Note: These figures have been rounded and therefore may not exactly match the Syringe Diameter Chart on page 112.

PHD ULTRA™ 4400 Flow Rates

Nominal Minimum/Maximum Flow Rates for Various Syringes.
(Actual Limits will vary depending on syringe manufacturer)

Syringe Size	Diameter *	Minimum	Maximum
0.5 µl	0.103 mm	3.0600 pl/min	1.59133 µl/min
1 µl	0.1457 mm	6.1200 pl/min	3.18423 µl/min
2 µl	0.206 mm	12.240 pl/min	6.36532 µl/min
5 µl	0.343 mm	33.960 pl/min	17.6471 µl/min
10 µl	0.485 mm	67.920 pl/min	35.2833 µl/min
25 µl	0.729 mm	153.480 pl/min	79.7151 µl/min
50 µl	1.030 mm	306.420 pl/min	159.133 µl/min
100 µl	1.457 mm	613.200 pl/min	318.423 µl/min
250 µl	2.304 mm	1.53348 nl/min	796.252 µl/min
500 µl	3.256 mm	3.06258 nl/min	1.59021 ml/min
1 ml	4.699 mm	6.37872 nl/min	3.31205 ml/min
2.5 ml	4.851 mm	6.79806 nl/min	3.52979 ml/min
3 ml	8.585 mm	21.915 nl/min	11.0552 ml/min
5 ml	11.989 mm	41.5232 nl/min	21.5601 ml/min
8 ml	9.525 mm	26.2093 nl/min	13.6087 ml/min
10 ml	14.427 mm	60.1280 nl/min	31.2204 ml/min
20 ml	19.050 mm	104.837 nl/min	54.4347 ml/min
30 ml	21.590 mm	134.658 nl/min	69.9183 ml/min
50 ml	26.594 mm	204.311 nl/min	106.085 ml/min
100 ml	34.900 mm	351.865 nl/min	182.699 ml/min
140 ml	37.950 mm	416.009 nl/min	216.005 ml/min

* Note: These figures have been rounded and therefore may not exactly match the Syringe Diameter Chart on page 112.

Pump 11 Elite Nanomite Flow Rates

Nominal Minimum/Maximum Flow Rates for Various Syringes.
(Actual Limits will vary depending on syringe manufacturer)

Syringe Size	Diameter *	Minimum	Maximum
0.5 µl	0.103 mm	3.66 pl/min	1.909 µl/min
1 µl	0.146 mm	7.32 pl/min	3.819 µl/min
2 µl	0.206 mm	14.70 pl/min	7.635 µl/min
5 µl	0.343 mm	40.74 pl/min	21.17 µl/min
10 µl	0.485 mm	81.48 pl/min	42.32 µl/min
25 µl	0.729 mm	184.1 pl/min	95.62 µl/min
50 µl	1.030 mm	367.6 pl/min	190.9 µl/min
100 µl	1.457 mm	735.6 pl/min	381.9 µl/min
250 µl	2.304 mm	1.839 nl/min	955.1 µl/min
500 µl	3.256 mm	3.677 nl/min	1.907 ml/min
1000 µl	4.608 mm	7.358 nl/min	3.820 ml/min

* Note: These figures have been rounded and therefore may not exactly match the Syringe Diameter Chart on page 112.

Syringe Pump Pressure and Flow Rate

Minimum/Maximum Flow Rates By Pump and Syringe Size

PHD ULTRA™ Flow Rates

Nominal Minimum/Maximum Flow Rates for Various Syringes.
(Actual Limits will vary depending on syringe manufacturer)

Syringe Size	Diameter *	Minimum	Maximum
0.5 µl	0.103 mm	1.500 pl/min	1.59133 µl/min
1 µl	0.1457 mm	3.060 pl/min	3.18423 µl/min
2 µl	0.206 mm	6.120 pl/min	6.36532 µl/min
5 µl	0.343 mm	16.980 pl/min	17.6471 µl/min
10 µl	0.485 mm	33.960 pl/min	35.2833 µl/min
25 µl	0.729 mm	76.740 pl/min	79.7151 µl/min
50 µl	1.030 mm	153.180 pl/min	159.133 µl/min
100 µl	1.457 mm	306.600 pl/min	318.423 µl/min
250 µl	2.304 mm	766.740 pl/min	796.252 µl/min
500 µl	3.256 mm	1.53126 nl/min	1.59021 ml/min
1 ml	4.699 mm	3.18936 nl/min	3.31205 ml/min
2.5 ml	4.851 mm	3.3990 nl/min	3.52979 ml/min
3 ml	8.585 mm	10.645 nl/min	11.0552 ml/min
5 ml	11.989 mm	20.7616 nl/min	21.5601 ml/min
8 ml	9.525 mm	13.1046 nl/min	13.6087 ml/min
10 ml	14.427 mm	30.0640 nl/min	31.2204 ml/min
20 ml	19.050 mm	52.4186 nl/min	54.4347 ml/min
30 ml	21.590 mm	67.3288 nl/min	69.9183 ml/min
50 ml	26.594 mm	102.156 nl/min	106.085 ml/min
100 ml	35.700 mm	184.091 nl/min	191.171 ml/min
140 ml	37.948 mm	208.005 nl/min	216.005 ml/min

* Note: These figures have been rounded and therefore may not exactly match the Syringe Diameter Chart on page 112.

Syringe Size	Diameter *	Minimum	Maximum
0.5 µl	0.10 mm	0.0001 µl/hr	95.330 µl/hr
1 µl	0.15 mm	0.0002 µl/hr	190.70 µl/hr
2 µl	0.21 mm	0.0004 µl/hr	381.30 µl/hr
5 µl	0.33 mm	0.0010 µl/hr	953.17 µl/hr
10 µl	0.46 mm	0.0019 µl/hr	1.901 ml/hr
25 µl	0.73 mm	0.0046 µl/hr	4.775 ml/hr
50 µl	1.03 mm	0.0092 µl/hr	9.551 ml/hr
100 µl	1.46 mm	0.0183 µl/hr	19.153 ml/hr
250 µl	2.30 mm	0.0454 µl/hr	47.532 ml/hr
500 µl	3.26 mm	0.0911 µl/hr	95.492 ml/hr
1000 µl	4.61 mm	0.0031 µl/min	190.950 ml/hr
1 ml	5.00 mm	0.0033 µl/min	205.30 ml/hr
2 ml	9.00 mm	0.0119 µl/min	747.35 ml/hr
2.5 ml	7.28 to 9.6 mm	0.0076 µl/min	476.21 ml/hr
3 ml	8.66 to 9.0 mm	0.0100 µl/min	11.231 ml/min
5 ml	10.3 to 13.0 mm	0.0208 µl/min	21.781 ml/min
10 ml	14.57 to 15.9 mm	0.0301 µl/min	31.486 ml/min
20 ml	19.13 to 20.05 mm	0.0523 µl/min	54.804 ml/min
30 ml	21.7 to 23.2 mm	0.0673 µl/min	70.518 ml/min
50 ml	26.7 to 32.6 mm	0.1019 µl/min	106.76 ml/min
100 ml	34.9 to 35.7 mm	0.1740 µl/min	182.40 ml/min
140 ml	38.40 mm	0.2106 µl/min	220.82 ml/min

Pump 33 DDS Flow Rates

Syringe Size	Diameter *	Minimum	Maximum
0.5 µl	0.103 mm	1.02 pl/min	1.06 µl/min
1 µl	0.146 mm	2.04 pl/min	2.13 µl/min
2 µl	0.206 mm	4.24 pl/min	4.08 µl/min
5 µl	0.343 mm	11.28 pl/min	11.75 µl/min
10 µl	0.485 mm	22.62 pl/min	23.5 µl/min
25 µl	0.729 mm	51.12 pl/min	53.09 µl/min
50 µl	1.030 mm	102.1 pl/min	106 µl/min
100 µl	1.457 mm	204.2 pl/min	212.1 µl/min
250 µl	2.304 mm	510.7 pl/min	530.2 µl/min
500 µl	3.256 mm	1.02 nl/min	1.059 ml/min
1000 µl	4.608 mm	2.043 nl/min	2.121 ml/min
1 ml	4.699 mm	2.124 nl/min	2.206 ml/min
3 ml	8.585 mm	7.091 nl/min	7.363 ml/min
5 ml	11.99 mm	13.83 nl/min	14.36 ml/min
10 ml	14.43 mm	20.03 nl/min	20.8 ml/min
20 ml	19.05 mm	34.91 nl/min	36.26 ml/min
30 ml	21.59 mm	44.84 nl/min	46.57 ml/min
50/60 ml	26.59 mm	68.02 nl/min	70.64 ml/min
50/60 ml	29.2 mm	82.03 nl/min	85.1 ml/min

Common Syringe Data

Diameter and Plunger Surface Area

The following list is a guide to common syringes and their associated diameters and surface area. Syringe diameter data, in mm, is listed below for each syringe. All Harvard Apparatus microprocessor syringe pumps require the user to input syringe diameter information. The pump uses this diameter data to set flow rates. The PHD 22/2000 series of syringe pumps also has this information built into the pump memory in a handy Syringe Look Up

Table. Surface area information was used to calculate PSI (pounds per square inch) data for the pressure on page 111. Average pressures for any syringe pump and syringe combination can be calculated by dividing the average (nominal) syringe pump force by the syringe diameter (in square inches) to obtain PSI. Example, nominal pressure obtained using a 25 ml Hamilton Gastight® Syringe on a PHD 22/2000 standard pressure syringe pump would

Common Syringe Diameters

Volume	Diameter (mm)	Surface Area (in ²)
BD Plastic		
1 ml	4.699	0.026880
3 ml	8.585	0.089722
5 ml	11.989	0.174980
10 ml	14.427	0.253381
20 ml	19.05	0.441786
30 ml	21.59	0.567450
50/60 ml	26.594	0.860974
BD Glass		
0.5 ml	4.64	0.026209
1 ml	4.64	0.026209
2.5 ml	8.66	0.091297
5 ml	11.86	0.171235
10 ml	14.34	0.250335
20 ml	19.13	0.445505
30 ml	22.7	0.627298
50 ml	28.6	0.995760
100 ml	34.9	1.482768
SGE Glass		
25 µl	0.73	0.000649
50 µl	1.03	0.001292
100 µl	1.46	0.002595
250 µl	2.3	0.006440
500 µl	3.26	0.012938
1 ml	4.61	0.025872
2.5 ml	7.28	0.064519
5 ml	10.3	0.129151
10 ml	14.57	0.258429

Common Syringe Diameters

Volume	Diameter (mm)	Surface Area (in ²)
Harvard Apparatus Stainless Steel		
2.5 ml	4.851	0.027937
8 ml	9.525	0.110447
20 ml	19.13	0.445505
50 ml	28.6	0.995760
100 ml	34.9	1.482768
200 ml	44.75	2.438382
Terumo Plastic		
3 ml	8.95	0.097514
5 ml	13	0.205735
10 ml	15.8	0.303904
20 ml	20.15	0.494279
30 ml	23.1	0.649601
60 ml	29.1	1.030881
Air-Tite All Plastic		
2.5 ml	9.6	0.112193
5 ml	12.45	0.188695
10 ml	15.9	0.307763
20 ml	20.05	0.489386
30 ml	22.9	0.638401
50 ml	29.2	1.037979
Cadence Science (formerly Popper & Sons) Perfectum Glass		
0.5 ml	3.45	0.014490
1 ml	4.5	0.024652
2 ml	8.92	0.096862
3 ml	8.99	0.098388
5 ml	11.7	0.166646
10 ml	14.7	0.263061
20 ml	19.58	0.466711
30 ml	22.7	0.627298
50 ml	29	1.023808
100 ml	35.7	1.551525

Common Syringe Diameters

Volume	Diameter (mm)	Surface Area (in ²)
Hamilton Gastight Glass		
0.5 µl	0.103	0.000013
1 µl	0.146	0.000026
2 µl	0.206	0.000052
5 µl	0.343	0.000129
10 µl	0.485	0.000258
25 µl	0.729	0.000647
50 µl	1.03	0.001294
100 µl	1.457	0.002595
250 µl	2.304	0.006440
500 µl	3.256	0.012938
1 ml	4.608	0.025872
2.5 ml	7.285	0.064519
5 ml	10.3	0.129151
10 ml	14.567	0.258429
25 ml	23.033	0.643989
50 ml	32.573	1.293772
100 ml	32.573	1.293772
Covidien Monoject Plastic (formerly Kendall)		
1 ml	4.674	0.026323
3 ml	8.865	0.097297
6 ml	12.600	0.196350
12 ml	15.621	0.307763
20 ml	20.142	0.506621
35 ml	23.571	0.689567
60 ml	26.568	0.861362
140 ml	37.948	1.795084

Syringe Selection Guide and Reglo Digital/Analog Flow Rates

Syringe Selection Guide

Syringe Type/ Size	Swage Lock	Luer Lock	RN	Threaded 1/4-28	Luer Slip Fit	Pressure Maximum p.s.i.	Compatibility with Substance in Syringe	Accuracy 1%	Accuracy 5%	Materials
Stainless Steel Syringes, see pages 46 to 47										
2.5 ml	•					7,500	Maximum	•		316 / St. Steel
8 ml	•					1,500	Maximum	•		316 / Perfluoroelastomer
20 ml	•	•				750	Maximum	•		316 / Viton or Perfluoroelastomer
50 ml	•	•				750	Maximum	•		316 / Viton or Perfluoroelastomer
100 ml	•	•				750	Maximum	•		316 / Viton or Perfluoroelastomer
200 ml	•	•				750	Maximum	•		316 / Viton or Perfluoroelastomer
Glass GasTight Syringes, see pages 47 to 53										
1 to 100 µl		•	•	•	•	1,000	Maximum	•		Glass and PTFE
250 to 500 µl		•	•	•	•	500	Maximum	•		Glass and PTFE
1 to 10 ml		•	•	•		200	Maximum	•		Glass and PTFE
25 to 100 ml		•	•	•		100	Maximum	•		Glass and PTFE
Plastic Syringes, see pages 54 to 55										
1 ml		•			•	125	Minimum		•	Polypropylene and Natural Rubber
5 ml		•			•	125	Minimum		•	Polypropylene and Natural Rubber
10 ml		•			•	125	Minimum		•	Polypropylene and Natural Rubber
20 ml		•			•	125	Minimum		•	Polypropylene and Natural Rubber
30 ml		•			•	125	Minimum		•	Polypropylene and Natural Rubber
50/60 ml		•			•	125	Minimum		•	Polypropylene and Natural Rubber
140 ml		•			•	125	Minimum		•	Polypropylene and Natural Rubber

REGLO Analog and Digital Pumps using 3-Stop Collared Tubing Flow Rates

AME#	3-STOP TUBING ID MM	REGLO Digital 2 Channel						REGLO Digital 4 Channel					
		MS-2/6-160 ML/MIN PER CHANNEL		MS-2/8-160 ML/MIN PER CHANNEL		MS-2/12-160 ML/MIN PER CHANNEL		MS-4/6-100 ML/MIN PER CHANNEL		MS-4/8-100 ML/MIN PER CHANNEL		MS-4/12-100 ML/MIN PER CHANNEL	
		Min.*	Max.	Min.*	Max.	Min.*	Max.	Min.*	Max.	Min.*	Max.	Min.*	Max.
00	0.13	0.003	0.22	0.002	0.17	0.002	0.15	0.002	0.14	0.002	0.11	0.001	0.093
01	0.19	0.005	0.45	0.004	0.37	0.004	0.34	0.003	0.28	0.003	0.23	0.003	0.21
02	0.25	0.008	0.76	0.007	0.65	0.007	0.6	0.005	0.48	0.005	0.41	0.004	0.38
03	0.38	0.017	1.7	0.015	1.5	0.014	1.4	0.011	1.1	0.01	0.94	0.009	0.88
04	0.44	0.023	2.3	0.020	2.0	0.019	1.9	0.014	1.4	0.013	1.3	0.012	1.2
05	0.51	0.061	3.1	0.027	2.7	0.025	2.5	0.019	1.9	0.017	1.7	0.016	1.6
06	0.57	0.038	3.8	0.033	3.3	0.031	3.1	0.024	2.4	0.021	2.1	0.019	1.9
07	0.64	0.048	4.8	0.042	4.2	0.039	3.9	0.03	3	0.026	2.6	0.024	2.4
08	0.76	0.067	6.7	0.058	5.8	0.053	5.3	0.042	4.2	0.036	3.6	0.033	3.3
09	0.89	0.090	9.0	0.079	7.9	0.071	7.1	0.057	5.7	0.049	4.9	0.044	4.4
10	0.95	0.10	10	0.089	8.9	0.079	7.9	0.064	6.4	0.056	5.6	0.05	5
11	1.02	0.12	12	0.10	10	0.090	9.0	0.073	7.3	0.063	6.3	0.056	5.6
12	1.09	0.13	13	0.11	11	0.10	10	0.083	8.3	0.072	7.2	0.063	6.3
13	1.14	0.14	14	0.12	12	0.11	11	0.09	9	0.078	7.8	0.067	6.7
14	1.22	0.16	16	0.14	14	0.12	12	0.1	10	0.088	8.8	0.075	7.5
15	1.3	0.18	18	0.16	16	0.13	13	0.11	11	0.1	10	0.083	8.3
16	1.42	0.21	21	0.18	18	0.15	15	0.13	13	0.11	11	0.094	9.4
17	1.52	0.24	24	0.20	20	0.17	17	0.15	15	0.13	13	0.1	10
18	1.65	0.28	28	0.23	23	0.19	19	0.17	17	0.15	15	0.12	12
19	1.75	0.31	31	0.26	26	0.20	20	0.19	19	0.16	16	0.13	13
20	1.85	0.34	34	0.28	28	0.21	21	0.21	21	0.17	17	0.13	13
21	2.06	0.40	40	0.33	33	0.24	24	0.25	25	0.2	20	0.15	15
22	2.29	0.46	46	0.38	38	0.27	27	0.29	29	0.24	24	0.17	17
23	2.54	0.53	53	0.44	44	0.31	31	0.33	33	0.27	27	0.19	19
24	2.79	0.59	59	0.50	50	0.34	34	0.37	37	0.31	31	0.21	21
25	3.1	0.68	68	0.57	57	0.38	38	0.43	43	0.35	35	0.24	24

*Note: Flow rate for REGLO Analog= 2% of Max Flow Rate

Note: Approximate values: determined with water at 22°C, no differential pressure, with Tygon® Tubing.

French Scale and Needle Gauge Cross Reference Chart

French Scale and Needle Gauge Cross Reference Chart								
French Scale	Exact French OD		Needle Gauge	Exact Gauge OD		Exact Gauge ID		Volume
	inches	mm		inches	mm	inches	mm	µl/in
–	0.0083	0.21	33	0.0083	0.21	0.0040	0.11	0.20
	0.0093	0.24	32	0.0093	0.24	0.0043	0.11	0.20
–	0.0103	0.26	31	0.0103	0.26	0.0053	0.13	0.34
–	0.0123	0.31	30	0.0123	0.31	0.0063	0.16	0.45
1	0.013	0.33	29	0.013	0.33	–	–	–
–	0.014	0.36	28	0.014	0.36	0.0073	0.18	0.63
–	0.016	0.41	27	0.016	0.41	0.0083	0.21	0.80
–	0.018	0.46	26	0.018	0.46	0.0103	0.26	1.25
1.8	0.024	0.61	25	0.023	0.51	0.0103	0.26	1.25
–	0.022	0.57	24	0.022	0.57	0.0123	0.31	1.80
2	0.026	0.66	23	0.025	0.64	0.0133	0.34	2.17
–	0.028	0.72	22	0.028	0.72	0.0163	0.41	3.35
2.4	0.031	0.79	21	0.032	0.82	0.0203	0.51	5.19
2.9	0.038	0.97	20	0.036	0.91	0.0238	0.60	6.71
3	0.039	0.99	–	0.039	0.99	–	–	–
3.3	0.043	1.09	19	0.042	1.07	0.0270	0.69	–
3.7	0.048	1.22	–	0.048	1.22	–	–	–
3.8	0.050	1.27	18	0.050	1.27	0.0330	0.84	14.08
4	0.052	1.32	–	0.052	1.32	–	–	–
4.6	0.060	1.52	17	0.058	1.47	0.0420	1.07	22.84
4.7	0.062	1.57	–	0.062	1.57	–	–	–
5	0.066	1.68	16	0.065	1.65	0.0470	1.19	28.25
5.1	0.067	1.70	–	0.067	1.70	–	–	–
5.7	0.075	1.91	15	0.072	1.83	0.0540	1.37	–
5.9	0.078	1.98	–	0.078	1.98	–	–	–
6	0.079	2.01	–	0.079	2.01	–	–	–
6.2	0.082	2.08	14	0.083	2.11	0.0630	1.60	51.07
7	0.092	2.34	–	0.092	2.34	–	–	–
7.2	0.095	2.41	13	0.095	2.41	0.0710	1.80	64.63
8	0.105	2.67	–	0.105	2.67	–	–	–
8.1	0.106	2.69	–	0.106	2.69	–	–	–
–	0.109	2.77	12	0.109	2.77	0.0850	2.16	93.07
8.4	0.118	3.00	11	0.120	3.05	0.0940	2.39	113.00
9.8	0.128	3.25	–	0.128	3.25	–	–	–
10	0.131	3.33	10	0.134	3.40	0.1060	2.69	143.28
11	0.145	3.68	–	0.145	3.68	–	–	–
11.7	0.153	3.89	–	0.153	3.89	–	–	–
12.3	0.161	4.09	–	0.161	4.09	–	–	–
13	0.171	4.34	–	0.171	4.34	–	–	–
14	0.184	4.67	–	0.184	4.67	–	–	–
15	0.197	5.00	–	0.197	5.00	–	–	–
16	0.210	5.33	–	0.210	5.33	–	–	–
17	0.223	5.66	–	0.223	5.66	–	–	–
18	0.236	5.99	–	0.236	5.99	–	–	–

* French Scale = OD (in) x 76.211 -0.0014

Pressure Unit Conversion Chart

Pressure Unit Cross Reference Chart

	atm	psi	cm H ₂ O	mm Hg	kPa	inch H ₂ O	inch Hg	mbar
1 atm =	1	14.696	1033.228	760	101.325	406.783	29.921	1013.25
1 psi =	0.068	1	70.307	51.715	6.895	27.68	2.036	68.948
1 cm H₂O =	0.001	0.0142	1	0.7356	0.0981	0.3937	0.0291	0.9807
1 mm Hg =	0.0013	0.0193	1.36	1	0.133	0.5352	0.039	1.333
1 kPa =	0.0099	0.145	10.197	7500.616	1	4.015	0.295	10
1 inch H₂O =	0.0025	0.036	2.54	1.868	0.2491	1	0.0736	2.491
1 inch Hg =	0.0334	0.4912	34.532	25399	3.386	13.595	1	33.864
1 mbar =	0.001	0.015	1.02	0.7501	0.1	0.4015	0.0295	1

Force Units Conversion Table

mN	mg-force	mp
0.1	10	10.2
0.2	20	20.39
0.3	30	30.59
0.4	40	40.79
0.5	50	50.99
0.6	60	61.18
0.7	70	71.38
0.8	80	81.58
0.9	90	91.77
1	100	101.97
2	200	203.94
3	300	305.91
4	400	407.89
5	500	509.86
6	600	611.83
7	700	713.8
8	800	815.77
9	900	917.74

1N = 1 Newton = 1 kg m/s²

1p = 1 Pond

Harvard Apparatus Peristaltic Minimum/Maximum Flow Rate by Tubing Size

Flow Rate by Tubing Size P-70				
Tubing Outer Diameter	Tubing Wall Thickness	Tubing Inner Diameter	Minimum Flow, ml/min	Maximum Flow, nl/min
(mm)	(mm)	(mm)		
1.73	1.6	0.13	0.525	0.166
1.79	1.6	0.19	1.121	0.356
1.85	1.6	0.25	1.942	0.616
1.93	1.6	0.38	4.487	1.425
2.1	1.6	0.5	7.769	2.467
2.23	1.6	0.63	12.33	3.918
2.36	1.6	0.76	17.95	5.701
2.48	1.6	0.88	24.06	7.644
2.62	1.6	1.02	32.33	10.27
2.74	1.6	1.14	40.38	12.82
2.89	1.6	1.29	57.71	16.42
3.02	1.6	1.42	62.66	19.9
3.12	1.6	1.52	71.8	22.8
3.25	1.6	1.65	84.6	26.87
3.45	1.6	1.85	106.3	33.78
3.65	1.6	2.05	130.6	41.48
3.98	1.6	2.38	176	55.91
4.14	1.6	2.54	200.5	63.68
4.39	1.6	2.79	241.9	76.84

Flow Rate by Tubing Size P-230				
Tubing Outer Diameter	Tubing Wall Thickness	Tubing Inner Diameter	Minimum Flow, ml/min	Maximum Flow, nl/min
(mm)	(mm)	(mm)		
1.95	1.82	0.13	1.35	0.521
2.01	1.82	0.19	2.88	1.112
2.07	1.82	0.25	4.99	1.926
2.2	1.82	0.38	11.5	4.451
2.26	1.82	0.44	15.4	5.967
2.33	1.82	0.51	20.7	8.017
2.39	1.82	0.57	25.9	10.01
2.46	1.82	0.64	37.7	12.62
2.48	1.72	0.76	46.1	17.08
2.61	1.72	0.89	63.3	24.41
2.67	1.72	0.95	72.1	27.81
2.74	1.72	1.02	83.1	32.06
2.81	1.72	1.09	94.9	36.62
2.86	1.72	1.14	103.8	40.05
2.94	1.72	1.22	118.9	45.87
3.02	1.72	1.3	135	52.09
3.14	1.72	1.42	161.1	62.15
3.24	1.72	1.52	184.6	71.21
3.37	1.72	1.65	217.5	83.91
3.47	1.72	1.75	244.7	94.39
3.57	1.72	1.85	273.5	105.4
3.78	1.72	2.06	339.1	130.8
4.01	1.72	2.29	419	161.6
4.26	1.72	2.54	515.5	198.8
4.51	1.72	2.79	622	239.9
4.99	1.72	3.17	803	309.7

Flow Rate by Tubing Size P-1500		
Tubing inner Diameter	Minimum Flow, ml/min	Maximum Flow, nl/min
(mm)		
0.8	0.028	15.34
1.6	0.113	61.37
3.2	0.454	245.4
4	0.71	383.5
4.8	1.022	552.3
6.4	1.818	981.9
8	2.841	1534.36



www.harvardbioscience.com

www.harvardapparatus.com

sales@harvardbioscience.com

Americas
(+1) 800-272-2775

Copyright © 2023 Harvard Bioscience, Inc. Product information is subject to change without notice. Harvard Apparatus is a trademark of Harvard Bioscience, Inc. or its affiliated companies. Harvard is a registered trademark of Harvard University. The mark Harvard Bioscience is being used pursuant to a license agreement between Harvard University and Harvard Bioscience, Inc.